

Enhancements for the Z4200 Truck Pump

CORKEN has enhanced the performance of the Z4200 truck pump. The industry leading enhancements improve the reliability and performance of the seal assembly, vanes, and vane drivers.

- **Improved Vane Design:**

A 100% increase in the surface area of the leading edge improves durability.

- **New Material for Vane Drivers:**

The new material is 60% stronger and lasts longer in high RPM applications.

- **Silicon Carbide Seal Seat:**

Offers unmatched sealing performance and a longer service life.

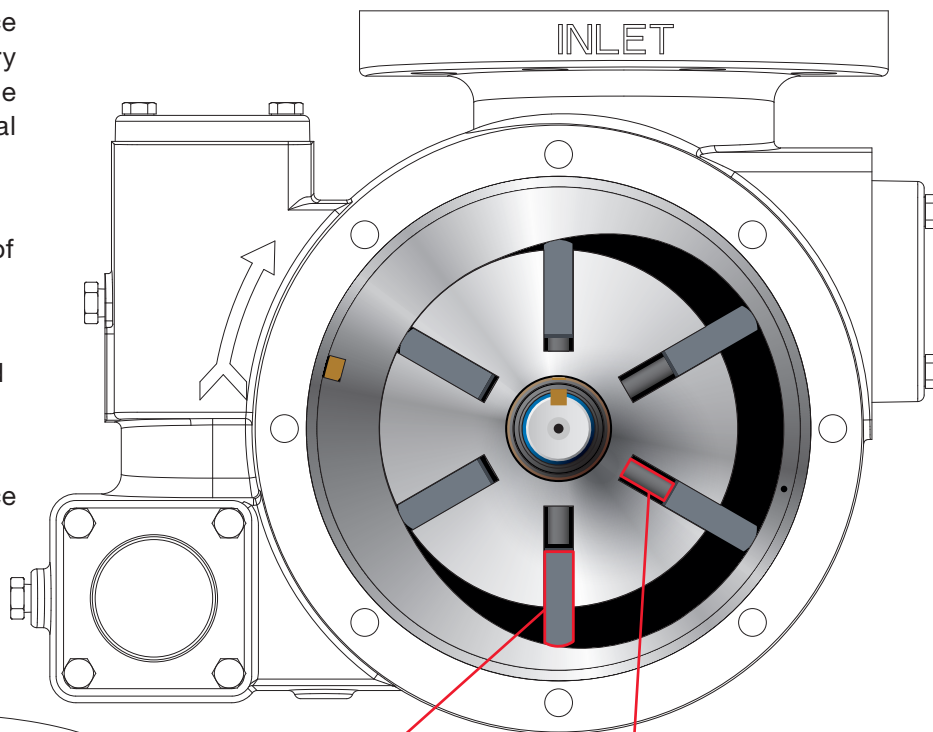

Leading Edge of Vane Has 2X the Thickness:

- Extends vane life
- Improves durability

Improved Vane Driver Material:

- 60% stronger
- Increased wear resistance and durability

Silicon Carbide Seal Seat:

- Maximizes sealing performance and durability
- Requires less maintenance

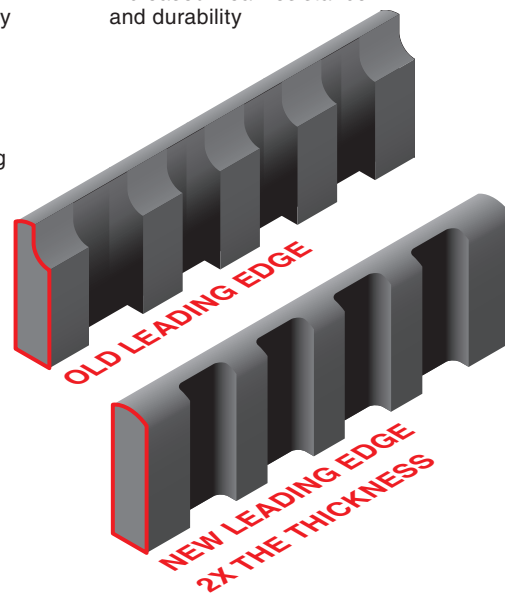
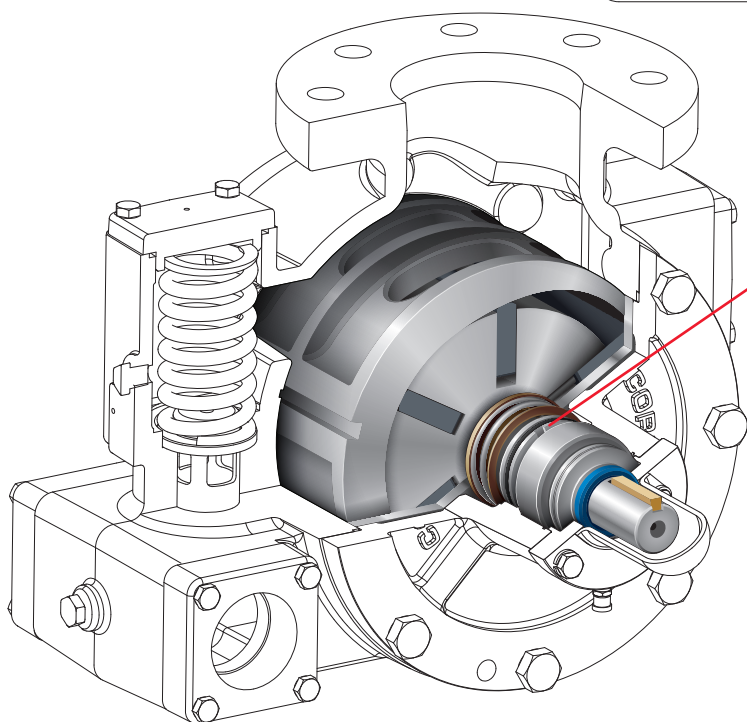

Solutions beyond products...

CORKEN

CORKEN, INC. • A Unit of IDEX Corporation
3805 NW 36th Street, Oklahoma City, OK 73112 U.S.A.
Phone (405) 946-5576 • FAX (405) 948-7343
Visit our website at www.corken.com
E-mail us at cocsalesdept@idexcorp.com



@CorkenInc

