

Extended Crankshaft is Now Standard on all Model 91 Compressors

Please note effective January 1, 2019, all model 91 compressors (91, F91, D91, FD91, T91, FT91) are shipped with the extended crankshaft. The previous option for the short crankshaft is no longer available so the extended crankshaft comes at no additional charge. The reason for this change is to provide more clearance between the crankcase, flywheel, and belt guard. A longer crankshaft makes it easier to mount the compressor and belt guard to the baseplate.

Listed below are the dimensions for a model 91 flywheel using the longer extended crankshaft with three different configurations. NOTE: Bare compressors are shipped with the flywheel in the same position as the direct drive option.

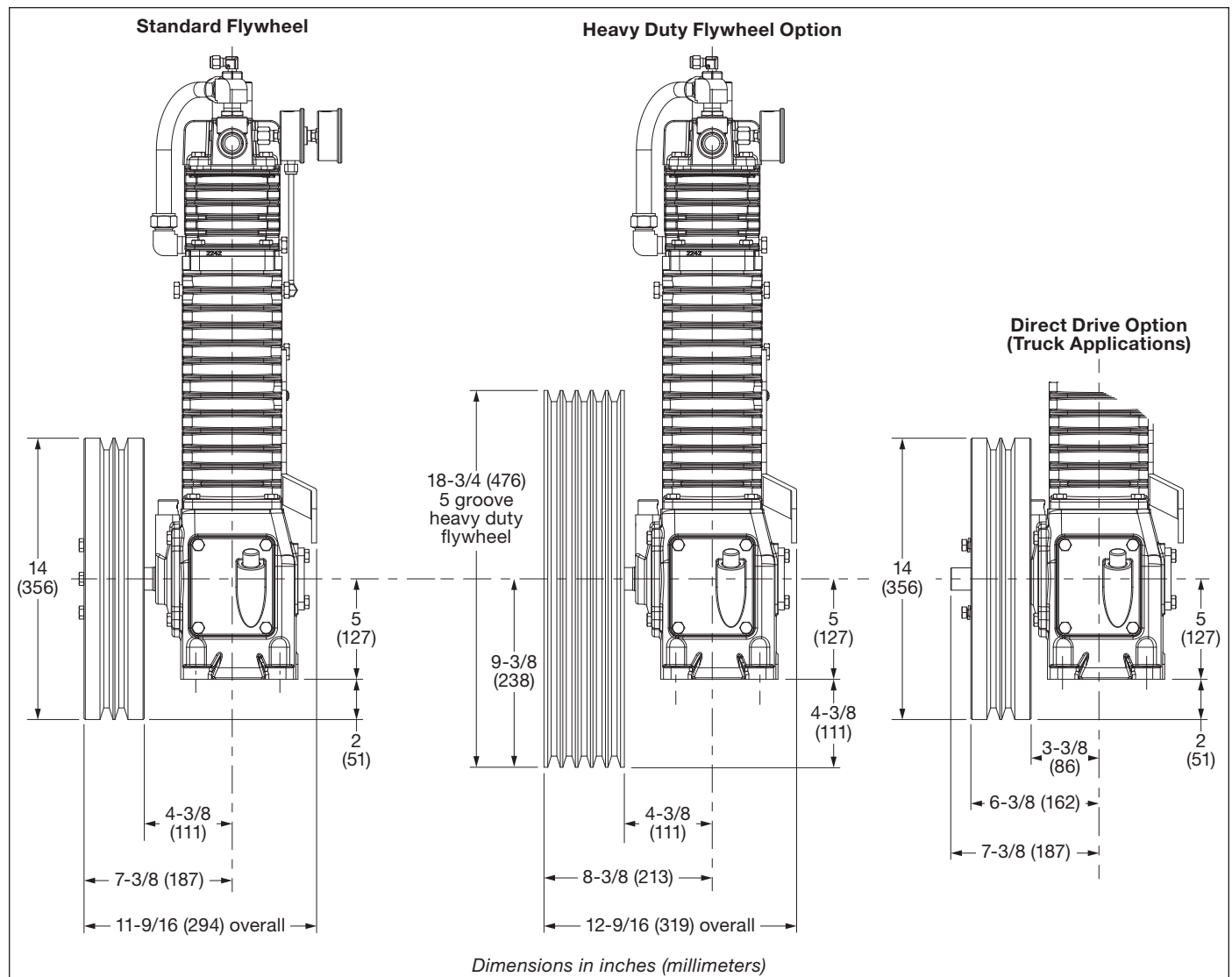

For illustration purposes, a model D91 is shown above but the dimensions apply to all model 91 compressors.

Solutions beyond products...

CORKEN®

CORKEN, INC. • A Unit of IDEX Corporation
3805 NW 36th Street, Oklahoma City, OK 73112 U.S.A.
Phone (405) 946-5576 • FAX (405) 948-7343
Visit our website at www.corken.com
E-mail us at cocsalesdept@idexcorp.com



@CorkenInc

