

LIQUEFIED GAS PUMP INSTALLATION

ENGINEERING DATA AND DESIGN HANDBOOK

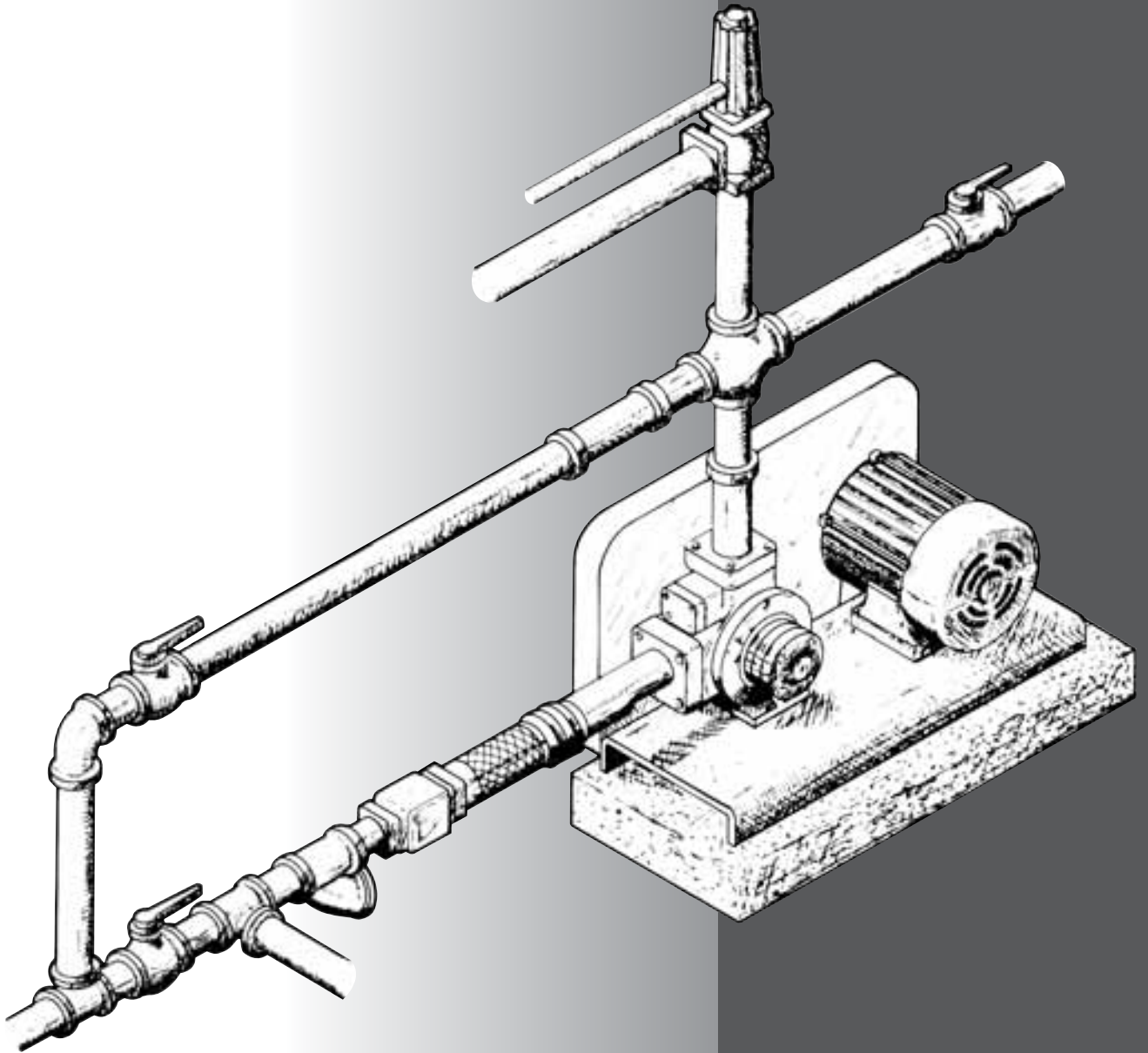

Solutions beyond products...

 **CORKEN**[®]
IDEX

THE APPLICATION OF PUMPS TO LIQUEFIED GAS TRANSFER



Of the many hundreds of pump manufacturers in the United States, only a handful recommend their equipment for transferring liquefied gases. There are various reasons for this, but the basic problem has to do with the nature of a liquefied gas. The specific peculiarity of a liquefied gas is that a liquefied gas is normally stored at its exact boiling point. This means that any reduction in pressure, regardless of how slight, or any increase in temperature, no matter how small, causes the liquid to start to boil. If either of these things happen in the inlet piping coming to the pump, the pump performance is severely affected. Pump capacity can be drastically reduced, the pump can be subjected to severe wear and the mechanical seal and the pump may run completely dry, causing dangerous wear and leakage.

Although we cannot change the nature of the liquefied gas, there are many things we can and must do to design an acceptable liquefied gas pumping system.

Many of these design hints are incorporated in the accompanying illustrations. You will note that each drawing is over-simplified and illustrates just one principle. Normal fittings, strainers, unions, flex lines, valves, etc. have been ignored so that just that portion of the piping which applies to the problem is shown. **Do not pipe a plant from these incomplete illustrations!** You should also note that all of these rules can be violated to a degree and still have a workable pumping system. You may see several places where your plant is at variance from some of these. However, you should be aware that every violation is reducing your pumping efficiency and increasing your pump maintenance cost. The principles apply to all makes and styles of liquefied gas pumps (rotary positive displacement, regenerative turbine or even centrifugal types).

This booklet is used in Corken Training Schools. Corken cooperates with gas marketers, trade associations and other groups to conduct complete training schools for persons involved in the transfer of liquefied gases. These presentations include product information, safety, plant design and equipment service/maintenance.

Warning: (1) Periodic inspection and maintenance of Corken products is essential. (2) Inspection, maintenance and installation of Corken products must be made only by experienced, trained and qualified personnel. (3) Maintenance, use and installation of Corken products must comply with Corken instructions, applicable laws and safety standards (such as NFPA Pamphlet 58 for LP-Gas and ANSI K61.1-1972 for Anhydrous Ammonia). (4) Transfer of toxic, dangerous, flammable or explosive substances using Corken products is at user's risk and equipment should be operated only by qualified personnel according to applicable laws and safety standards.



CORKEN, INC. • A Unit of IDEX Corporation
3805 N.W. 36th St., Oklahoma City, OK 73112
Phone (405) 946-5576 or 1-800-631-4929
Fax (405) 948-7343

Visit our website at <http://www.corken.com>
or e-mail us at info.corken@idexcorp.com

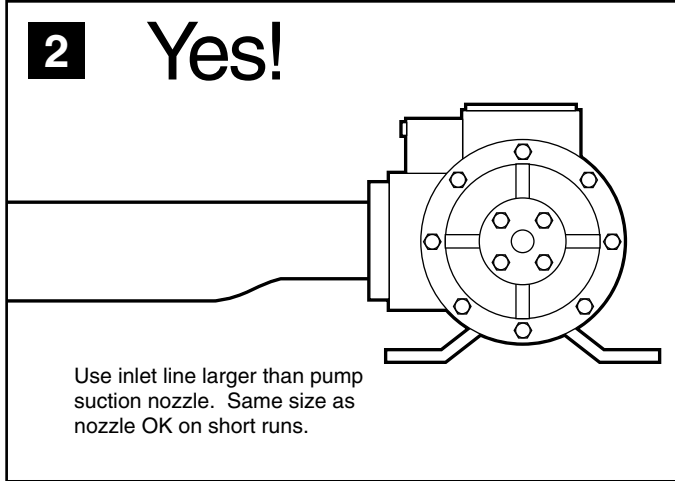
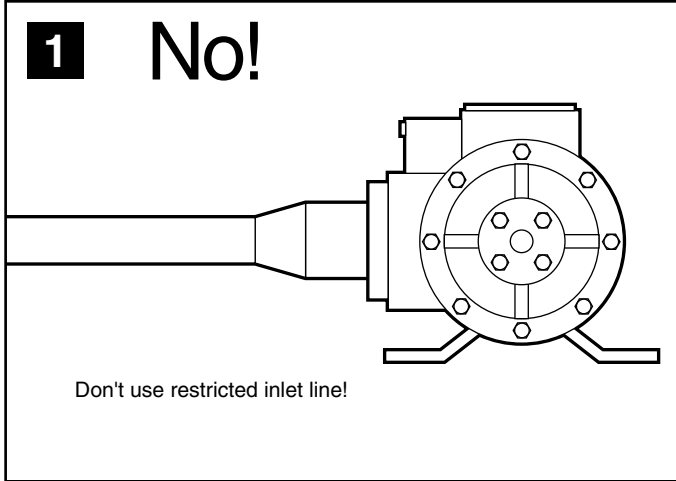

Pressure drop caused by restriction in suction line will cause vaporization and cavitation.

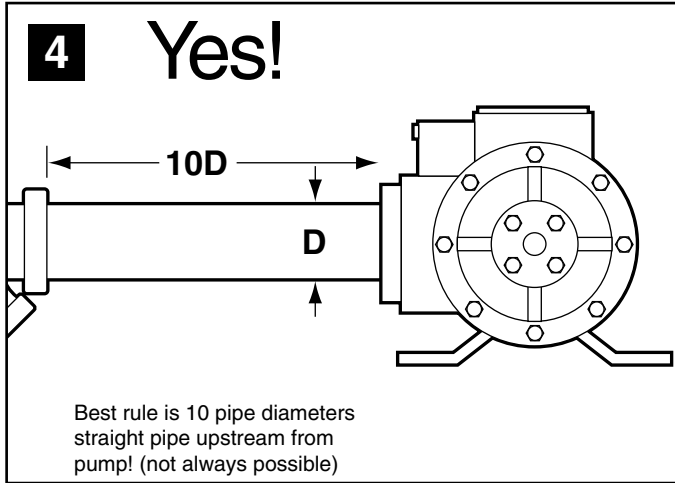
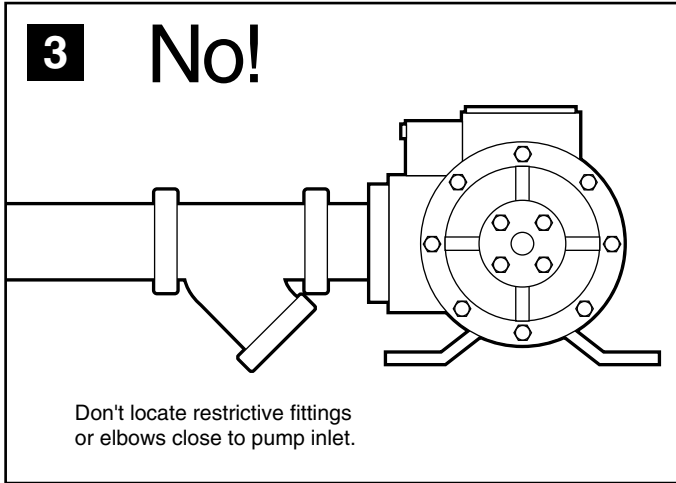

Turbulence caused by flow interference close to the pump accentuates incipient cavitation.

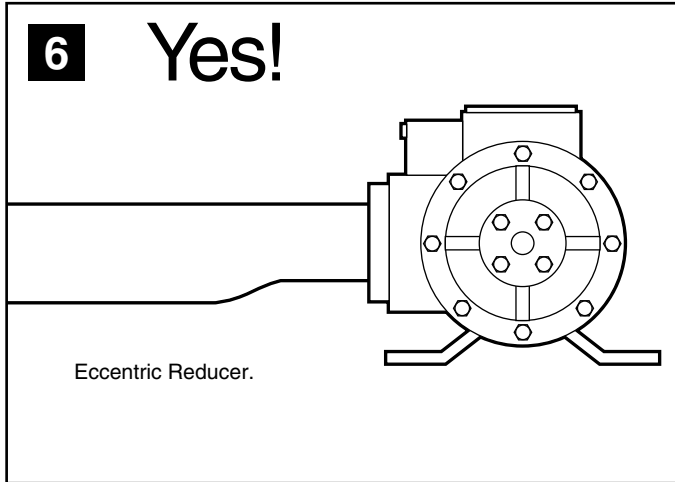
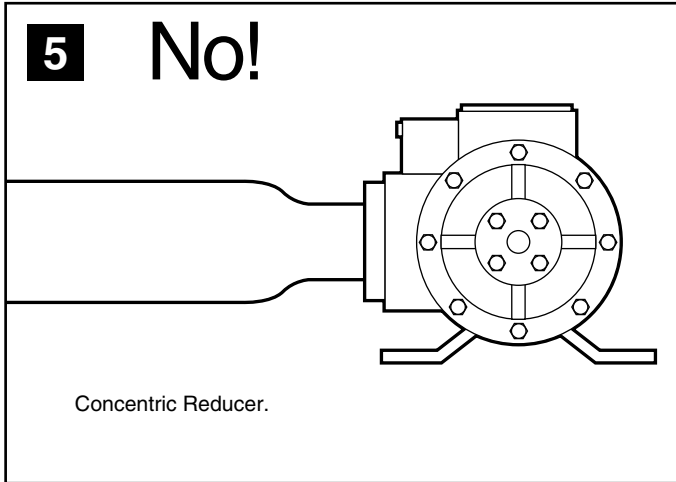

An eccentric reducer should always be used when reducing into any pump inlet where vapor might be encountered in the pumpage. The flat upper portion of the reducer prevents an accumulation of vapor that could interfere with pumping action.

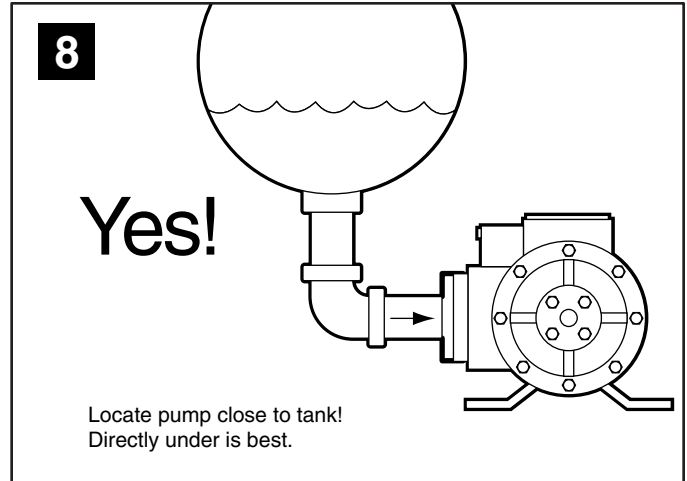
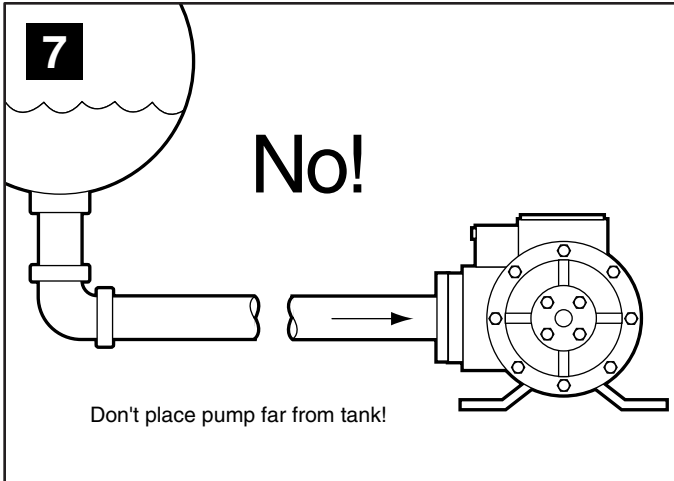

It is best to allow the pump to be fed by gravity flow to give stable, trouble-free operation.

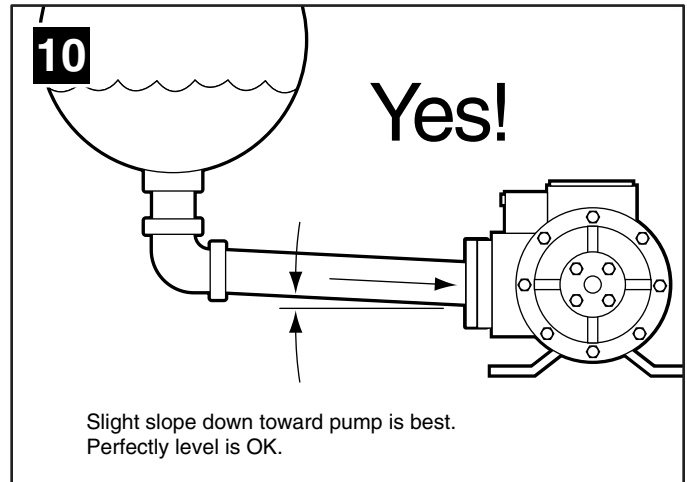
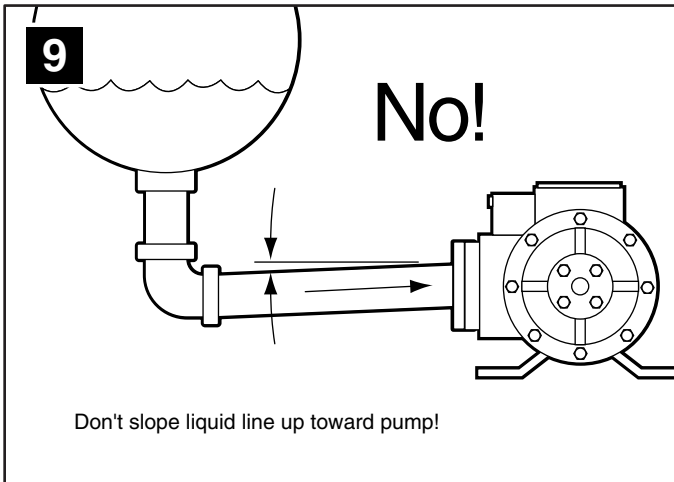

Vaporization in the pump inlet line can displace liquid in the pump so that pump may start up in a dry condition. A slope toward the pump of only an inch or two in a 10 foot run will allow vapor to gravitate back into the tank and be replaced with liquid.

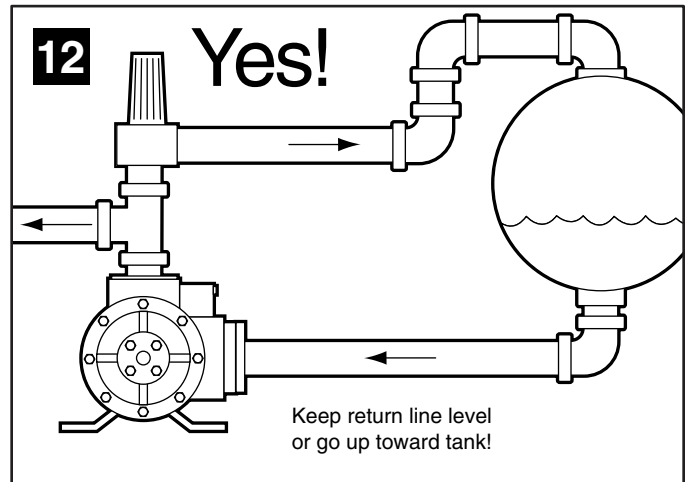
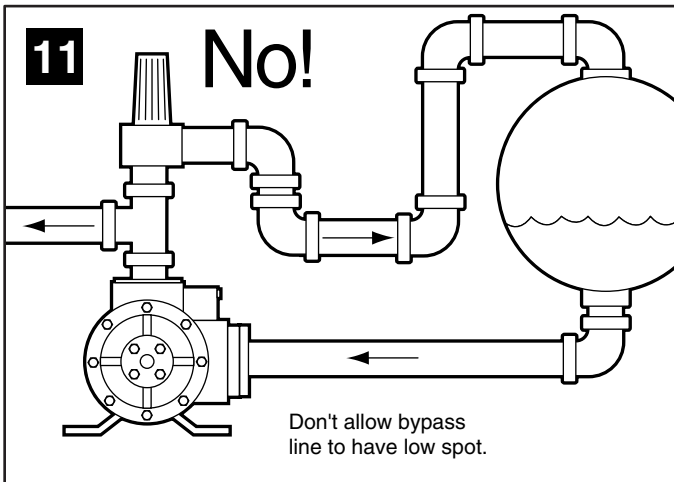

Low spots in bypass line can collect liquid which prevents normal vapor passage for priming purposes just like the P trap in the drain of a kitchen sink. This is not a problem for bypass lines where vapor elimination is not required.

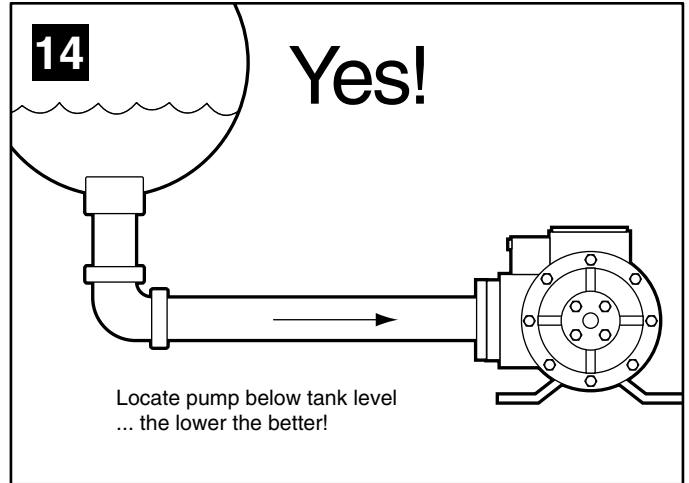
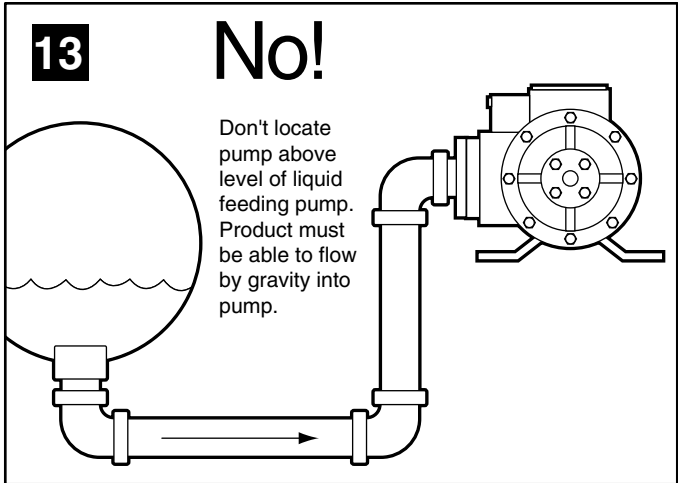

Since liquefied gases boil when drawn into a pump by its own suction, the pump must be fed by gravity flow to give stable, trouble-free operation.

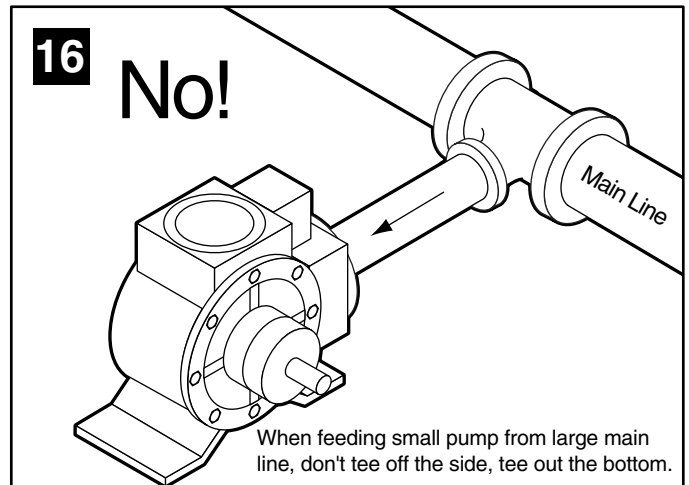
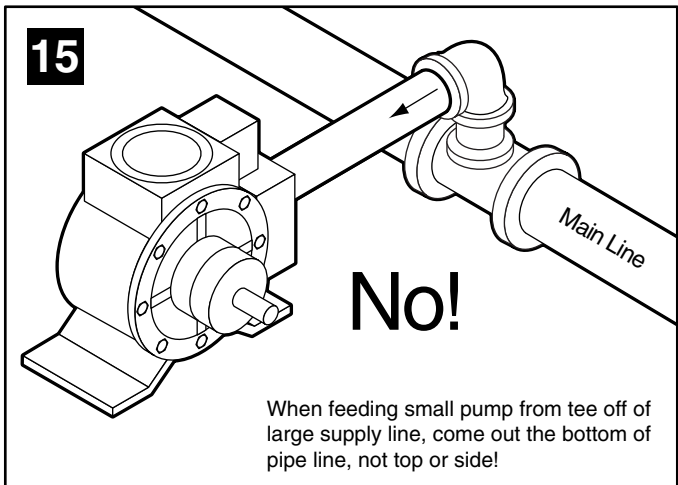

Low capacity flow through large lines often does not sweep out vapor. Flow occurs like liquid in a flume. Drawings 15 and 16 would allow vapor slugs to be drawn into the small pump causing erratic performance. Drawing 17 shows the best chance for stable feed into a small pump from a large line.

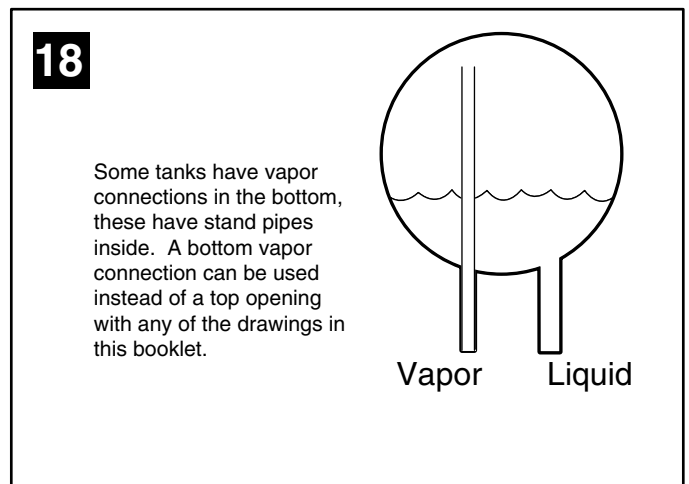
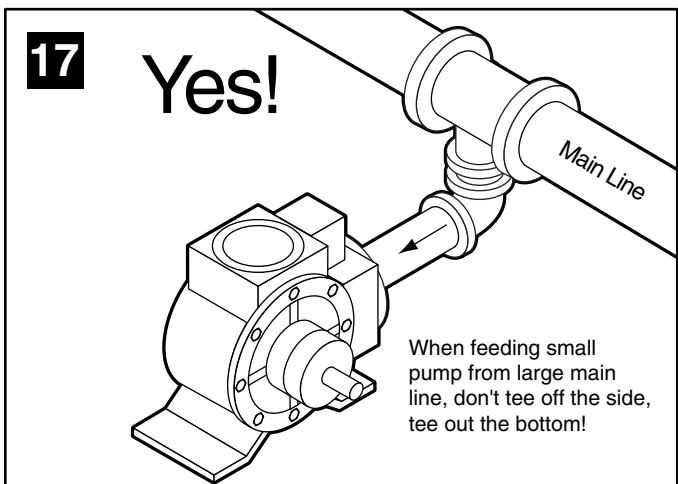

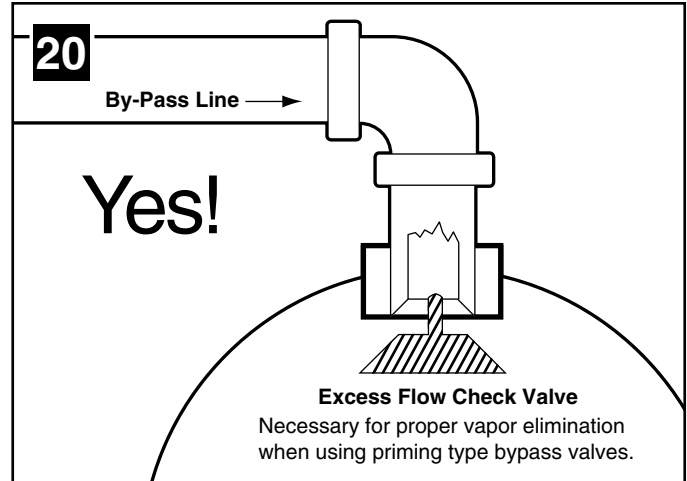
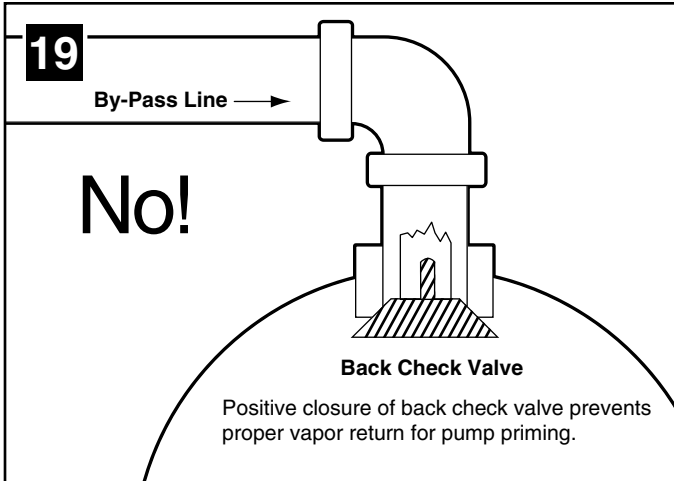

This is not a problem where vapor elimination is not required.

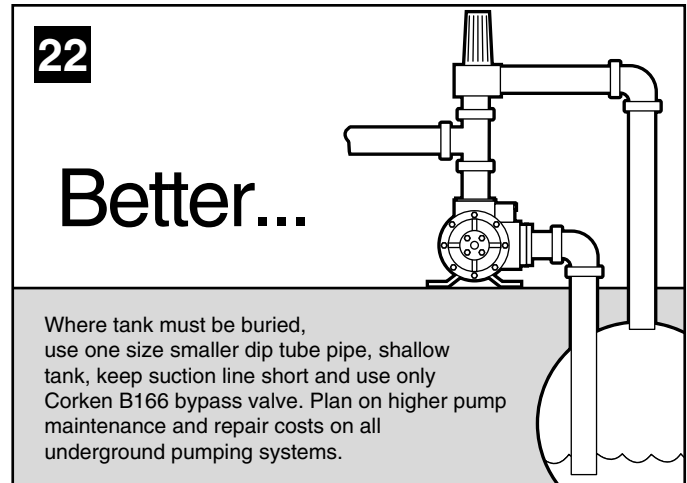
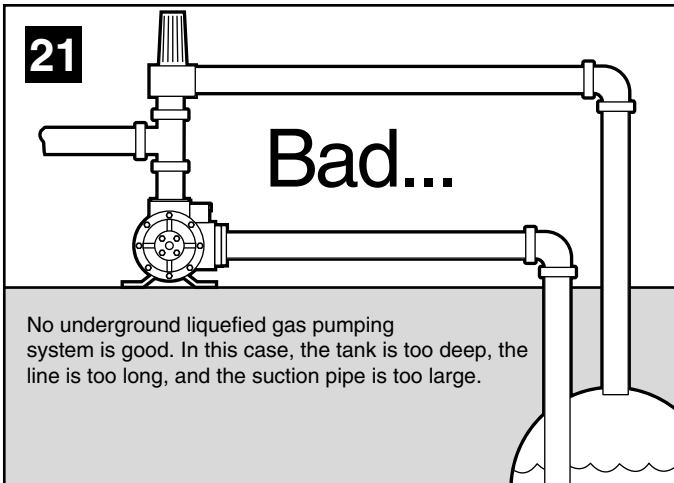

Where pumping from underground storage must be done, consult instruction book IF103.

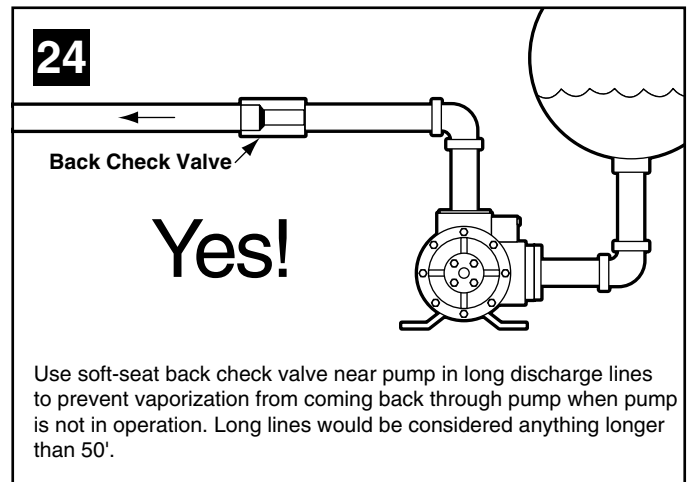
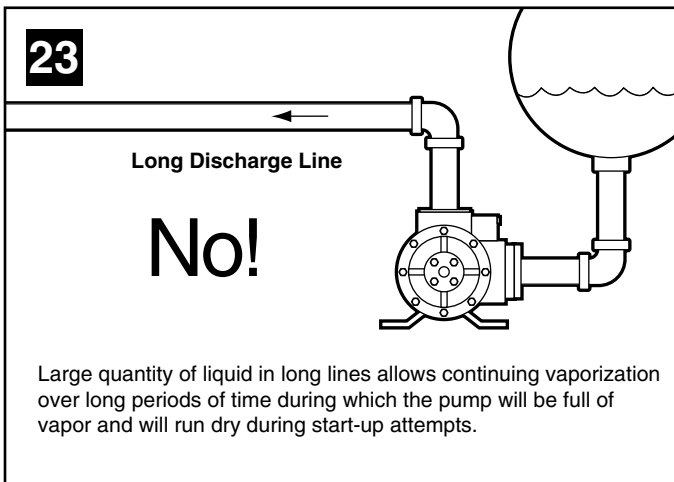

25

Bad...

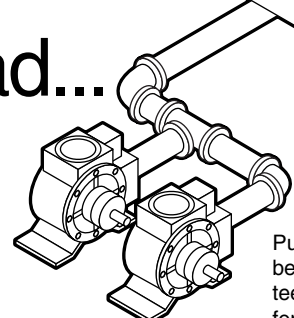

Pump No. 1 is starved because of venturi action at tee. This would be acceptable for installations where both pumps would never operate at the same time.

26

OK...

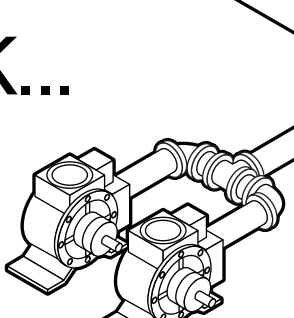

Pumps operating in parallel.

27

Good...

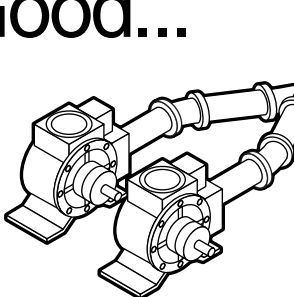

Multiple pumps fed from same main line.

28

Best...

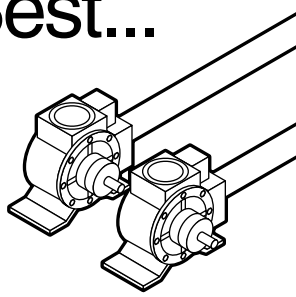

Parallel piping of liquefied gas pumps.

Inquire about Corken's duplex-series pump set.

29 No!

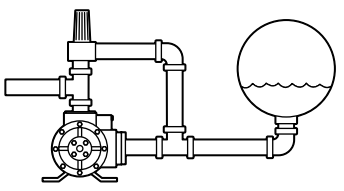

Don't pipe bypass line back into suction piping! Heat buildup in recirculated products causes flashing of liquid to vapor with immediate cavitation and ultimate dry-running. This is why the bypass relief valves which are built into many positive displacement pumps should not be used for normal bypass action when handling liquefied gases. The internal valve should be considered to be a back-up safety relief in addition to a back-to-tank bypass valve and should be set to relieve at a pressure 10 to 20 psi higher than the working bypass. Some built-in bypass valves have the capability of being piped back-to-tank so check with the pump manufacturer.

30 Yes!

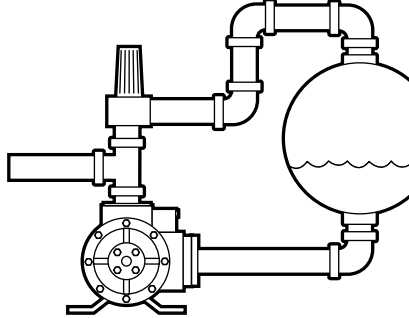

Always pipe bypass back to tank! Make sure bypass line is large enough to handle full pump flow without excessive pressure build-up. Note that bypass line must be capable of bypassing full pump capacity without excessive pressure build-up. High pressure rise can cause bypass valve to chatter and vibrate.

31 No!

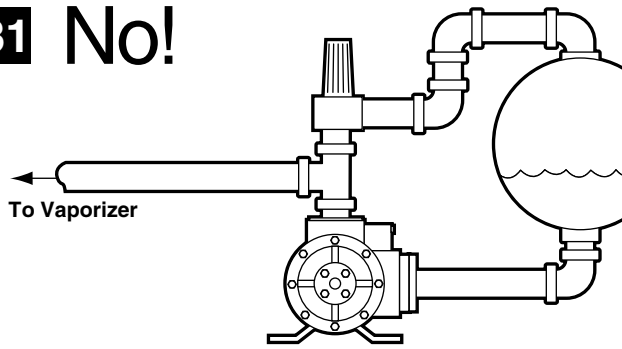

On vaporizer feed pumps, a back check valve should be installed between the pump and to prevent back-flow of vapor from entering pump.

32 No!

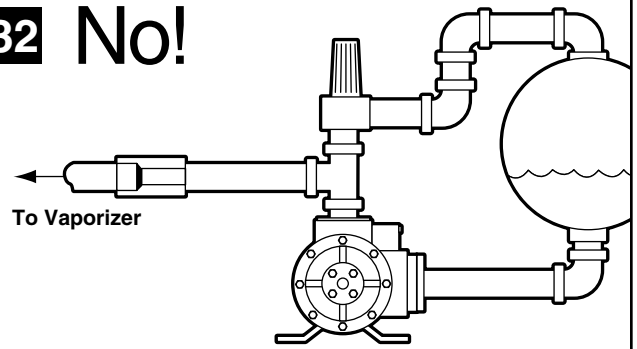

Back check must be located to allow back-flow into tank from vaporizer.

33 Better...

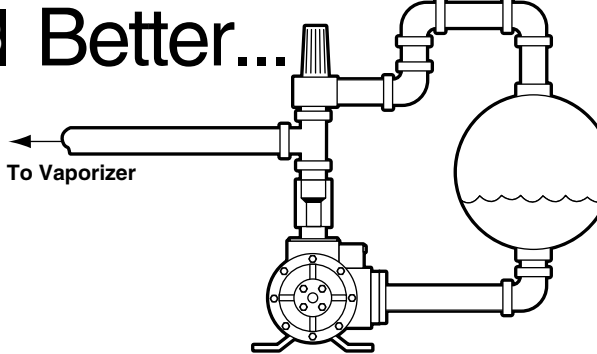

Back check valve protects pump but allows back flow through bypass valve into storage tank. **Use back check without spring loaded valve to allow normal vapor elimination.**

34 Best

Where A is a constant pressure bypass control valve and B is Corken B166 bypass and vapor elimination valve.

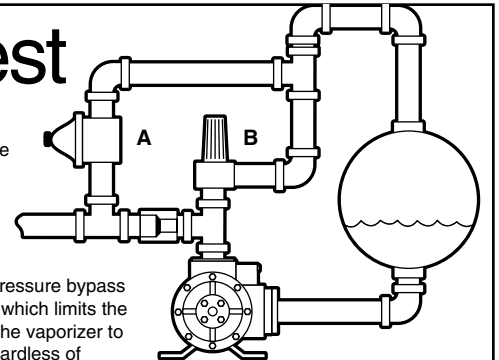

Valve A is a fixed pressure bypass like the Fisher 98H which limits the feed pressure into the vaporizer to a specific value regardless of system vapor pressure. A differential bypass valve like the Corken B166, T166, or B177 controls a fixed difference in pressure between the pump discharge and the tank. Differential valve B must be set to the maximum acceptable differential of the pump while fixed pressure valve A is set for the vaporizer pressure requirement.

35

Corken B166 Bypass Valve Functions.

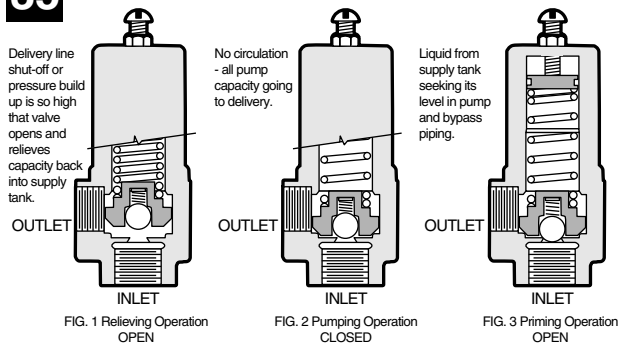

For pump capacities under 100 GPM, use a bypass valve with built-in vapor elimination where possible, like Corken's B166 or T166 valves.

36

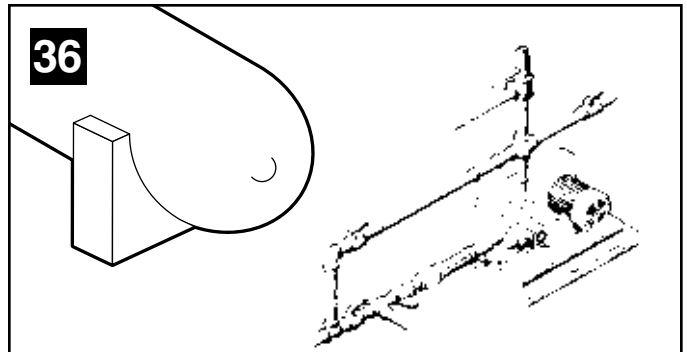

Some bypass valves, like the Corken B177, require tank pressure sensing lines. Check instructions for your valve.

Summary

1. Minimize pressure losses in pump suction line. Pressure drop causes increased vaporization which, in turn, causes decreased pump performance and increased pump maintenance.
2. Avoid vapor traps in pump suction line and liquid traps in pump bypass lines. Vapor pockets in the pump inlet cause erratic pump performance and liquid pockets in bypass lines interfere with vapor elimination from the system.
3. Control vapor from backing up into pump from the discharge line.
4. Minimize heat buildup in the pumping system by piping bypass liquid back to the tank rather than directly to the pump inlet.
5. Maximize the elevation difference between the tank and the pump.
6. Always use equipment approved for use with LP-gas and carefully follow the requirements of NFPA.
7. Do not pipe a plant from the drawings shown here. They are schematic only and intended to illustrate specific piping principles.