

MODELS 91, 291, 491, 691
MOUNTING STYLES -107, -107A
OUTLINE DIMENSIONS

MAY 1996
 SUPERSEDES VE301G

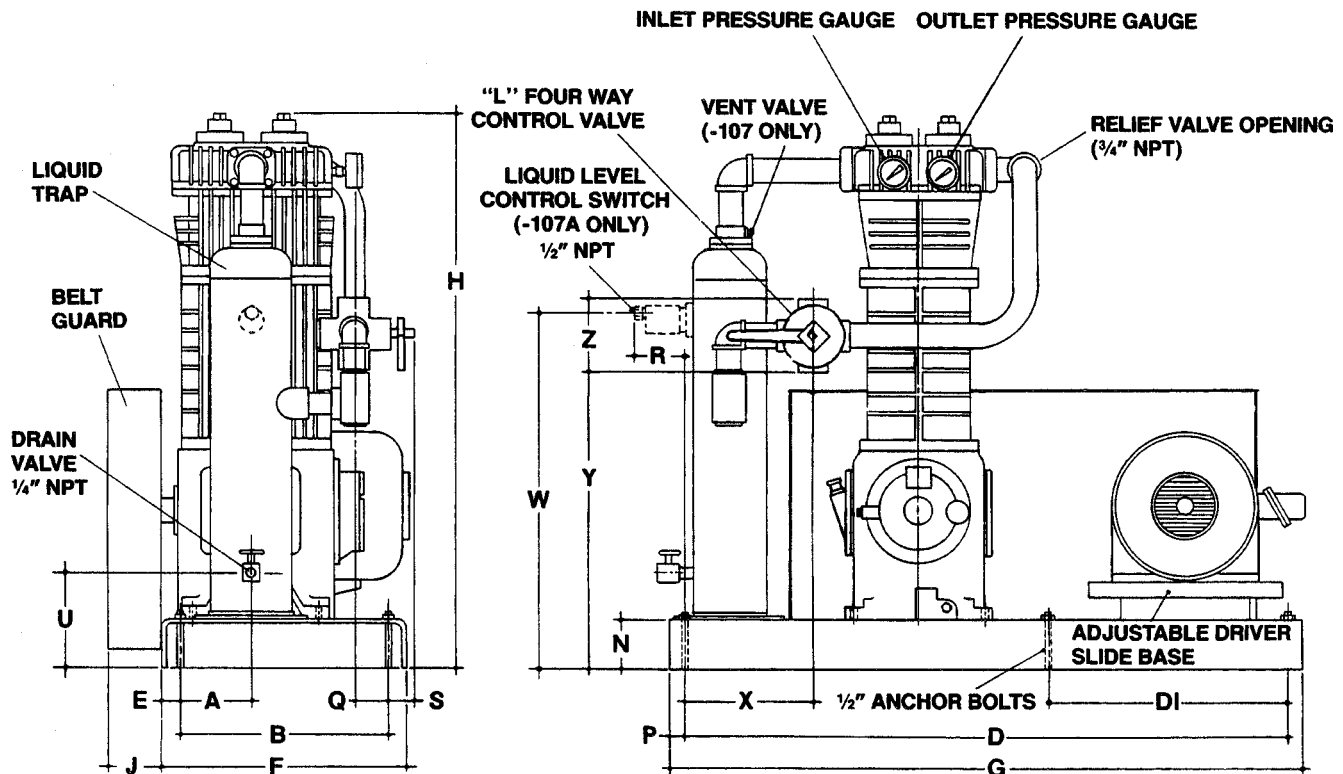

DIMENSIONS IN INCHES (CENTIMETERS)										
MODEL NO.	A	B	D	D1	E	F	G	H	J	L
91-107, 91-107A	5 (12.7)	12 (30.4)	31½ (80.0)	-	1½ (3.8)	15 (38.1)	34 (86.4)	30¾ (78.4)	5 (12.7)	1 NPT
291-107, 291-107A	5 (12.7)	12 (30.4)	39½ (100)	-	1½ (3.8)	15 (38.1)	42 (107)	30¾ (78.4)	5 (12.7)	1 NPT
491-107, 491-107A	5¾ (14.6)	15 (38.1)	45½ (116)	-	1½ (3.8)	18 (45.7)	48 (122)	33¾ (85.7)	5 (12.7)	1¼ NPT
691-107, 691-107A	8¼ (21.0)	17 (43.1)	49½ (126)	19¾ (50.1)	1½ (3.8)	20 (50.8)	52 (132)	43¼ (110)	5½ (14)	1¼ NPT

MODEL NO.	N	P	Q	R	S	U	W	X	Y	Z
91-107, 91-107A	3 (7.6)	1¼ (3.2)	0	3/8 (9.2)	2¼ (5.7)	6¾ (17.1)	17 (43.0)	8½ (21.7)	18 (45.0)	4 (10.1)
291-107, 291-107A	3 (7.6)	1¼ (3.2)	0	4³/₁₆ (10.6)	2¼ (5.7)	6¾ (17.1)	17 (43.0)	9¼ (23.4)	18 (45.0)	4 (10.1)
491-107, 491-107A	4 (10.1)	1¼ (3.2)	2¾ (7.0)	4 (10.1)	3/₁₆ (0.47)	7¾ (19.6)	18 (46.0)	9¾ (24.7)	19¾ (48.0)	6 (15.0)
491-107, 691-107A	4 (10.1)	1¼ (3.2)	¼ (0.63)	4¾ (10.4)	2¹¹/₁₆ (6.8)	7¾ (19.6)	29 (73.0)	10½ (26.6)	24¼ (61.0)	6 (15.0)

DIMENSIONS ARE APPROXIMATE — CERTIFIED PRINTS AVAILABLE ON REQUEST