

IMPORTANT INSTRUCTIONS

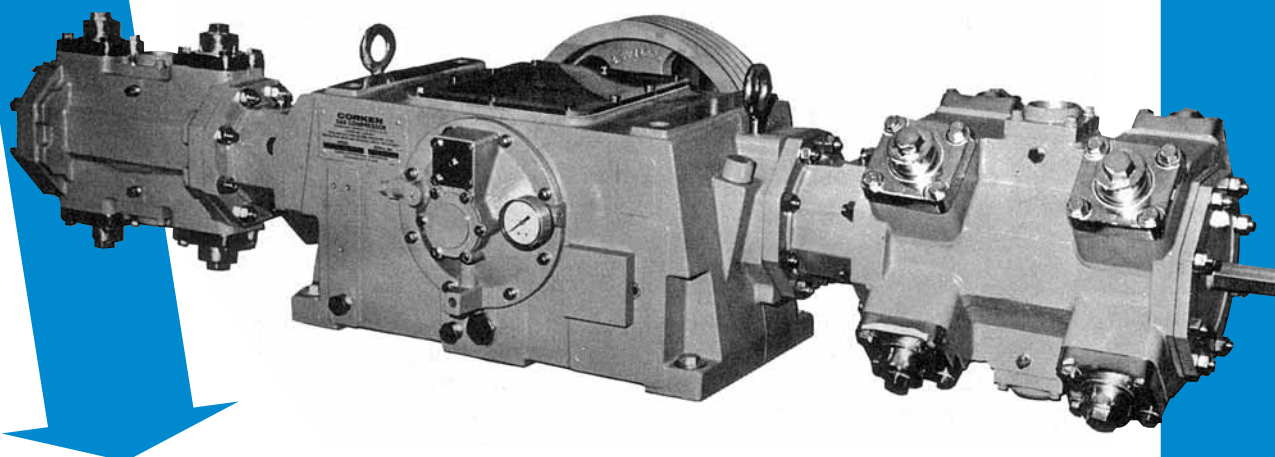

HORIZONTAL GAS COMPRESSORS

WARNING: (1) Periodic inspection and maintenance of Corken products is essential. (2) Inspection, maintenance and installation of Corken products must be made only by experienced, trained and qualified personnel. (3) Maintenance, use and installation of Corken products must comply with Corken instructions, applicable laws and safety standards (such as NFPA Pamphlet 58 for LP-Gas and ANSI K61.1-1972 for Anhydrous Ammonia). (4) Transfer of toxic, dangerous, flammable or explosive substances using Corken products is at user's risk and equipment should be operated only by qualified personnel according to applicable laws and safety standards.

CORKEN[®]
IBEX

WARNING

Install, use and maintain this equipment according to CORKEN, INC. instructions and all applicable federal, state, local laws and codes, and NFPA Pamphlet 58 for LP-Gas or ANSI K61.1-1972 for Anhydrous Ammonia. Periodic inspection and maintenance is essential.

CORKEN ONE YEAR LIMITED WARRANTY

CORKEN, INC. warrants that its products will be free from defects in material and workmanship for a period of 12 months following date of purchase from CORKEN.

CORKEN products which fail within the warranty period due to defects in material or workmanship will be repaired or replaced at CORKEN's option, when returned, freight prepaid, to CORKEN, INC., 3805 N.W. 36th Street, Oklahoma City, Oklahoma 73112.

Parts subject to wear or abuse, such as mechanical seals, blades, piston rings, and packing, and other parts showing signs of abuse are not covered by this limited warranty. Also, equipment, parts and accessories not manufactured by CORKEN but furnished with CORKEN products are not covered by this limited warranty and the purchaser must look to the original manufacturer's warranty, if any. This limited warranty is void if the CORKEN product has been altered or repaired without the consent of CORKEN.

All implied warranties, including any implied warranty of merchantability or fitness for a particular purpose, are expressly negated to the extent permitted by law and shall in no event extend beyond the expressed warranty period.

CORKEN DISCLAIMS ANY LIABILITY FOR CONSEQUENTIAL DAMAGES DUE TO BREACH OF ANY WRITTEN OR IMPLIED WARRANTY ON CORKEN PRODUCTS. Transfer of toxic, dangerous, flammable or explosive substances using CORKEN PRODUCTS **is at user's risk**. Such substances should be handled by **experienced, trained personnel in compliance with governmental and industrial safety standards**.

WRITING THE FACTORY

If you have occasion to write the factory about your equipment, please tell us the Serial Number. This Serial Number directs us to a file containing all information on material specifications and test data applying to your unit as well as when it was built. For your convenience, the Model and Serial Numbers are shown on the nameplate of the unit. Space is provided below for you to keep a written record of this information.

Always include the Model and Serial Numbers when ordering parts. This assures you of getting the correct replacements for your machine. The construction details in these instructions are for reference only; your CORKEN Service Manual should be consulted for the actual Part Numbers.

Model No. _____ Serial No. _____

Date Purchased _____ Date Installed _____

Purchased from _____

Installed by _____

**CORKEN
HORIZONTAL GAS COMPRESSORS
Installation - Operation - Maintenance**

INSTRUCTIONS

CONTENTS

Mechanical Specifications (Table 1)	1
Installation of Your Compressor	1
Location	1
Piping	1
Driver Installation	2
Initial Operation of Your Compressor	2
Lubrication	3
Oil Pressure Adjustment	3
Compressor Speed and Rotation	3
V-Belt Adjustment	3
Startup After Extended Shutdown	3
Force Feed Cylinder Lubrication	4
Variable Clearance Heads	4
Startup Checklist	4
Repair Service on Your Compressors	5
Routine Maintenance	5
Valve Repair and Inspection	5
Packing Replacement and Inspection	7
Dry Cylinder Compressors	7
Lubricated Cylinder Compressors	7
Assembling or Changing Cylinders on Horizontal Compressors	7
Compressor Trouble Shooting	8
General	8
Two-Stage Compressor Trouble Shooting	8
Extended Shutdown Procedures	9
External Lubricators.....	9
Torque Specifications	11
Log Sheet	12

CORKEN HORIZONTAL GAS COMPRESSORS

Your new Corken compressor is a horizontal double acting reciprocating compressor. Corken horizontal compressors are available in a number of variations to fit your individual needs. They are manufactured as single stage or two stage units; mechanical specifications are given in Table 1.

TABLE 1. Mechanical Specifications

MODEL	HG601AA	HG601BB	HG601DD	HG601EE	HG602AB	HG602BD	HG602BE
SIZE	8 X 8	6 X 6	4 X 4	3.25 X 3.25	8 X 6	6 X 4	6 X 3.25
# STAGES	1	1	1	1	2	2	2
# CYLINDERS PER STAGE	2	2	2	2	1	1	1
DISPLACEMENT 100 RPM CFM (M3/HR)	34.5 (58.6) 103 (175) 414 (703)	19.2 (32.7) 58 (99) 231 (393)	8.3 (14.1) 24.9 (42) 99.6 (169)	5.3 (9.1) 16 (27) 64 (109)	17.2 (29.3) 52 (88) 207 (352)	9.6 (16.3) 29 (49) 115 (195)	9.6 (16.3) 29 (49) 115 (195)
APPROX. WEIGHT (LBS.) (W/O FLYWHEEL)	820	660	620	595	740	645	630

CYLINDER DATA

SIZE IN. (MM)		8 (203)	6 (152)	4 (101.6)	3.25 (83)
WORKING PRESSURE PSIG (BAR G)		300 (21)	350 (24)	1000 (69)	1200 (83)
CLEARANCE %	CRANK END	12.6	14.5	20.3	17.4
	HEAD END	11.6	12.6	15.6	10.8
	AVERAGE	12.1	13.5	17.9	14.1
HEAD END VAR. CLEARANCE	MAXIMUM % (HE)	38.7	35.8	36.0	29.7
	MAXIMUM % (AVG)	25.9	25.4	28.6	24.1
	% PER TURN (HE)	2.13	1.93	1.70	1.48
	% PER TURN (AVG)	1.08	0.99	0.89	0.78
PISTON AREA IN ² (CM ²)	CRANK END	49.0 (316)	27.0 (174)	11.3 (73)	7.1 (45.6)
	HEAD END	50.3 (324)	28.3 (182)	12.6 (81)	8.3 (53.5)
DISPLACEMENT CRANK END PER 100 RPM CFM (M3/HR) HEAD END PER 100 RPM TOTAL PER 100 RPM		8.51 (14.46) 8.73 (14.83) 17.24 (29.29)	4.70 (7.99) 4.91 (8.34) 9.61 (16.33)	1.97 (3.35) 2.18 (3.70) 4.15 (7.05)	1.23 (2.09) 1.44 (2.45) 2.67 (4.54)
VALVE AREA PER CORNER IN ² (CM ²)		3.58 (23.1)	2.70 (17.4)	1.35 (8.7)	0.61 (3.9)
APPROX. MAXIMUM DIFF. PRESS. PSI (BAR)		145 (10)	265 (18)	590 (41)	900 (62)

FRAME DATA

STROKE IN. (MM)		3 (76)
MAX. ROD LOAD LB (KG)		7500 (3400)
MAX. MOTOR SIZE HP (KW)		
CONTINUOUS	60 (45)	
INTERMITTENT	75 (56)	
MAX. DISCH TEMP F (C)		350 (177)

Compressor Sheave: 4 Groove 5V16.0 (Minimum)
5 Groove 5V21.2 (Standard)

NOTE: 5V cross-section belts are modern cross-section V-belts which can transmit much more horsepower than conventional V-belts in the same drive space. For these compressors, 5V belts can transmit well in excess of the crankcase rating. Low compressor speeds generally result in a smaller motor sheave which may require 5VX belts.

INSTALLATION OF YOUR COMPRESSOR

LOCATION

Proper installation of your compressor is essential for peak performance and reliable service. Installation should be in a clean, ample space. A minimum of 18 in. clearance between the unit and the nearest wall is advised to make it accessible from all sides and to provide unrestricted air flow for adequate cooling of the motor and compressor. The unit should be firmly bolted to a solid, level base.

PIPING

The compressor piping should be designed for the rate of flow anticipated and for minimum pressure drop; in no case should the piping be smaller than the compressor nozzle to which it connects. If the length of the line must exceed 100 ft., the next larger size pipe should be used. Never install a shut-off valve in the discharge piping unless a safety relief valve is placed in the line between the shut-off valve and the compressor. Care must be taken that the compressor head does not support the piping. Adequate supports and sufficient piping flexibility must be provided to absorb mechanical vibration and gas pulsation. Install a strainer at the compressor inlet. Remember to consider future expansion in your pipe sizing and layout.

A reciprocating compressor is designed to handle gas (vapor), not liquid! A liquid trap (scrubber) must be installed in the suction piping (and discharge line if condensate can drain back to the compressor) when handling any but the driest of gases.

DRIVER INSTALLATION

The wiring of an electric motor is extremely important, and must be done by a competent electrician. Improper motor wiring will cause you to experience expensive motor difficulties from low voltage. If you suspect that you have a low voltage problem, call your power company.

A humid climate can cause problems, particularly in explosion proof motor applications. The normal breathing of the motor, and alternating between being warm when running and being cool when stopped, often will cause moist air to be drawn into the motor housing. This moist air will condense, and may eventually add enough free water to the inside of the motor to cause it to fail. To prevent this, make a practice of running the motor at least once a week on a bright, dry day for an hour or so without the V-belts. In this period of time the motor will heat up and vaporize the condensed moisture, driving it from the motor. No motor manufacturer will guarantee his explosion proof or totally enclosed (TEFC) motor against damage from moisture.

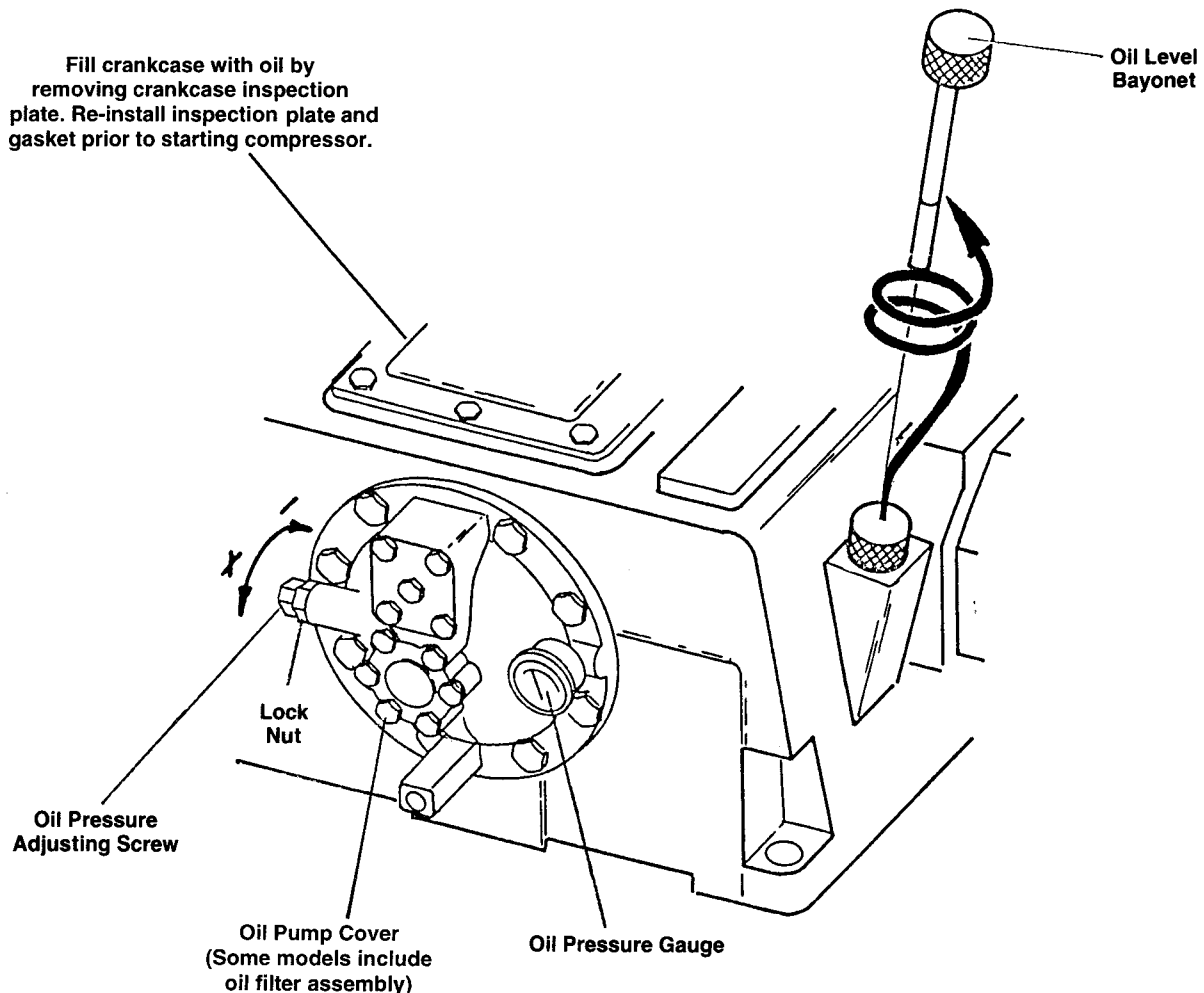

FIGURE 1. Oil Pressure Adjustment

INITIAL OPERATION OF YOUR COMPRESSOR

Initial operation of your compressor is the most critical time it will ever face. READ THIS SECTION CAREFULLY — IT WILL SAVE YOU MONEY AND INCREASE THE SAFETY OF YOUR OPERATION!

LUBRICATION

The crankcase of your compressor was drained before shipment. Before starting the machine be sure to fill the crankcase to, but not above, the full mark on the oil bayonet. The type of oil should be a heavy duty non-detergent motor oil with rust and oxidation inhibitors of a viscosity shown in Table 3. (See Fig. 1 for proper oil filling location.)

OIL PRESSURE ADJUSTMENT (See Fig. 1)

When the compressor is first started, observe the crankcase oil pressure gauge. If the gauge fails to indicate pressure within 30 seconds, stop the machine. Remove the pressure gauge and loosen the oil pump cover slightly. Restart the compressor and run it until oil comes out of the pressure gauge opening. Tighten the cover and install the gauge.

The oil pressure should be at least 20 psi for normal service. If the discharge pressure is above 200 psi then oil pressure must be maintained at a minimum of 25 psi. The oil pressure is regulated by a spring-loaded relief valve mounted on the bearing housing opposite the sheave. Turn the adjusting screw clockwise to increase the oil pressure and counterclockwise to lower it. Be sure to loosen the adjusting-screw locknut before trying to turn the screw, and tighten it after making any adjustment.

COMPRESSOR SPEED AND ROTATION DIRECTION

The lubrication system of the CORKEN HG600 compressor is designed to operate a minimum of 400 RPM. If lower speeds are necessary, consult the factory. The maximum speed of the HG600 is 1200 RPM. The crankshaft may be rotated in either direction.

COMPRESSOR COOLING

AIR COOLED: Double acting units generate a lot of heat around the valve area. It is very important that the compressor be located where good air flow and ventilation can be provided. In extreme cases external cooling fans can be used to provide additional air flow across the cylinders.

WATER COOLED: If your unit has water cooled cylinders (optional), be sure that the cooling system has been inspected for leaks and proper circulation. Purge air from the cooling jackets to eliminate air pockets in the cooling system. If chilled water systems are used be sure that water shut-off valves are installed to stop water flow when compressor stops. Monitor system for any signs of internal sweating. If detected, water temperatures and flow rates should be checked. Normal flow rate for cylinders is approximately 1 - 2 GPM.

V-BELT ADJUSTMENT

Improper belt tension and sheave alignment can cause vibration, excessive belt wear and premature bearing failures. Before operating your compressor, check alignment of the V-grooves of the compressor and driver sheaves; visual inspection often will indicate if the belts are properly aligned, but use of a square is the best method.

Before working on the drive assembly be sure that the electric power is off. Always make sure the driver and Compressor are close enough together to avoid forcing when mounting the belts. Tighten the belts so that they are taut, but not extremely tight. Consult your V-Belt supplier for specific tension recommendations. Belts that are too loose will cause excessive vibration while those that are too tight may cause premature bearing failure.

STARTUP AFTER EXTENDED SHUTDOWN

If your compressor has been out of service for a long period of time, you should verify that the cylinder bore and valve areas are free of rust and other debris. (See the maintenance section of the manual for valve and/or cylinder head removal instructions.) In addition, the crankcase cover should be removed to ensure that no water has condensed in it. Squirt oil on the X-heads and rotate the crank by hand to ensure that all bearing surfaces are coated with oil, then replace the crankcase cover.

ACCEPTABLE CRANKCASE OIL PRODUCTS FOR CORKEN COMPRESSORS				
Constant Weight - Nondetergent - R&O Inhibited				
Oil Product	ISO	VI	SAE	Ambient Temp.
Exxon®				
TERESSTIC	100	95	30	65°- 100° F
	68	95	20+	45°- 70° F
	46	95	20	35°- 50° F
Mobil®				
RARUS 427 Reciprocating Compressor Oil	100	95	30	65°- 100° F
DTE Oil Heavy Medium	64	95	20+	45°- 100° F
Dectol R&O Oil	44	95	20	35°- 50° F
Conoco®				
Dectol R&O Oil	100	98	30	35°- 50° F
	68	97	20+	45°- 70° F
	46	99	20	35°- 50° F
Texaco®				
Regal R&O Oil	100	92	30	65°- 100° F
	68	97	20+	45°- 70° F
	46	102	20	35°- 50° F
Sun®				
SunVis 900 Oil	100	100	30	65°- 100° F
	68	100	20+	45°- 70° F
	46	100	20	35°- 50° F

TABLE 3. Oil Selection Chart

New compressors are shipped with a special oil designed to cling to metal surfaces. However, these special procedures are still worthwhile as it may have been some time since the unit was actually shipped from the factory.

FORCE FEED CYLINDER LUBRICATION (lubed models only)

The standard lubricator is bolted directly to the crankcase and is driven by a chain inside the crankcase at 80% of crankshaft speed. Refer to the lubricator instruction sheet for:

- A. Priming instructions.
- B. Adjusting pump flow rate.
- C. Operating & maintenance instructions.

The lube pump should be set at maximum capacity for the first hour of operation. Then, reduce the flow to the break-in rate for a week. At that time the pump flow can be reduced to normal operating levels. These rates should be noted on the logsheet (CP-217).

VARIABLE CLEARANCE HEADS

Variable clearance outboard head assemblies are supplied on many units to allow compressor adjustment for changing operating conditions. Variable Clearance Heads allow for capacity and Bhp requirements of the cylinder to be varied. Normally, the Packager will have already provided at least a preliminary adjustment of the V.C.H. If not, you may wish to adjust the heads for maximum clearance before startup. Then, the heads can be adjusted inward, increasing the capacity and BHP of the cylinder to the desired levels.

To adjust the Variable Clearance Heads:

- A. Remove the V.C.H. adjusting bolt cap.
(Adjustment may be done with the unit running.)
- B. Turn the adjusting bolt to adjust the cylinder head end clearance.
Turning the bolt in reduces cylinder head end clearance.
Turning the bolt out increases cylinder head end clearance.
For percent clearance change per turn of the adjusting bolt, please refer to Table 1, Compressor Mechanical Specifications.
- C. Replace the V.C.H. adjusting bolt cap.

LOG SHEET (CP-217)

Use the log sheet in this manual on a regular basis. This will enable you to detect changes in operating conditions and give you the opportunity to correct problems while they are still small (and inexpensive!). If you need more copies, call the factory and ask for CP-217.

STARTUP CHECKLIST

Please verify all of the items on this list before starting your compressor! Failure to do so may result in a costly (or dangerous) mistake.

Before Starting the Compressor:

1. Become familiar with the function of all piping associated with the compressor. Know each line's use!
2. Verify that actual operating conditions will match the anticipated conditions.
3. Ensure that line pressures are within cylinder pressure ratings.
4. Clean out all piping.
5. Check that packing vents are open and tubed to proper locations.
6. All mounting shims, cylinder and piping supports should be checked to ensure that no undue twisting forces exist on the compressor.
7. Verify that strainer elements are in place and clean.
8. Verify that cylinder bore and valve areas are clean.
9. Check V-belt tension and alignment. Check drive alignment on direct drive units.
10. Bar over unit by hand.
11. Check all fluid levels (crankcases, lubricator, radiator, oil reservoirs, etc.).
12. Drain all liquid traps, separators, etc.
13. Verify proper electrical supply to motor & panel.
14. Check that all gauges are at zero level reading.
15. Test piping system for leaks.
16. Purge unit of air before pressurizing with gas.

17. Check all water piping and controls (water cooled units).
18. Carefully check for any loose connections or bolts.
19. Remove all stray objects (rags, tools, etc.) from vicinity of unit.
20. Verify that all valves are open or closed as required.
21. **Double check all of the above!**

After Starting Compressor

1. Verify & note proper oil pressure. Shut down and correct any problem immediately.
2. Observe noise & vibration levels. Correct immediately if excessive.
3. Verify proper compressor speed.
4. Examine entire system for gas, oil, or water leaks.
5. Note rotation direction.
6. Check start-up voltage drop, running amperage and voltage at motor junction box.
7. Verify proper lube rate (lubed units only).
8. Test each shutdown device and record set points.
9. Test all dump valves, relief valves, and unloaders.
10. Check & record all temperatures, pressures, and volumes after 30 min. and 1 hour.
11. After 1 hour running time, tighten all bolts.

REPAIR SERVICE ON YOUR COMPRESSORS

ROUTINE MAINTENANCE

If routine maintenance is performed as outlined in Table 4, repair service on your CORKEN gas compressor is generally limited to replacing valves or piston rings. Specific parts details and service information are show on Service Manual Pages J2 through J1412

TABLE 4. Routine Maintenance Chart

ITEM TO CHECK	DAILY	WEEKLY	MONTHLY	6 MONTHS	YEARLY
CRANKCASE OIL PRESSURE	X				
COMPRESSOR DISCHARGE PRESSURE	X				
OVERALL VISUAL CHECK	X				
CRANKCASE OIL LEVEL			**	**	
DRAIN MOISTURE FROM ACCUMULATION POINTS		X			
DRAIN DISTANCE PIECE		X			
CLEAN COOLING SURFACES ON COMPRESSOR AND INTERCOOLER		X			
LUBRICATOR SUPPLY TANK LEVEL		X			
CHECK BELTS FOR CORRECT TENSION			X		
INSPECT AND CLEAN FILTER FELTS ON CONTROL PILOT (VALVE SPEC. 78,8)			X		
INSPECT AND CLEAN FILTER FELTS ON CRANKCASE HYDRAULIC UNLOADER (VALVE SPEC. 7.78)			X		
INSPECT VALVE ASSEMBLIES				X	
LUBRICATE MOTOR BEARINGS IN ACCORDANCE WITH MANUFACTURERS' RECOMMENDATIONS				X	
INSPECT MOTOR STARTER CONTACT POINTS					X
PISTON RINGS				*	X

*Piston Ring Life vareies greatly depending on application, gas, and operating pressures. Consult factory for additional recommendations for your specific applications.

**Change oil and filter every 1000 hours of operation or every 3 months, whichever occurs first. If the oil is unusually dirty or contaminated by the process gas, change it as often as needed to maintain a clean oil condition.

VALVE REPAIR AND INSPECTION (See Fig. 2)

Before starting to work be sure the compressor is vented and depressurized, and power disconnected.

1. Remove the valve cap.
2. Remove the holddown screw; a special Corken wrench is provided. (If the holddown screw comes out with the cap, separate them).
3. Remove the bolts and valve cover plate.
4. Remove the valve cage.

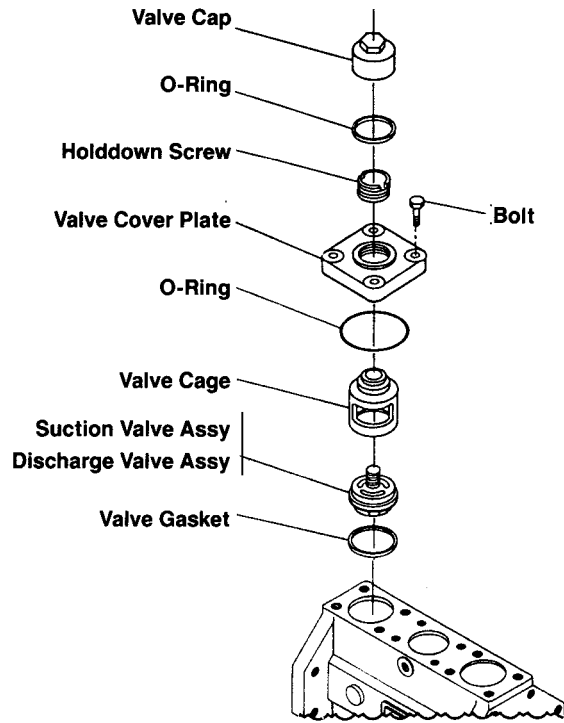

FIGURE 2. Valve Removal

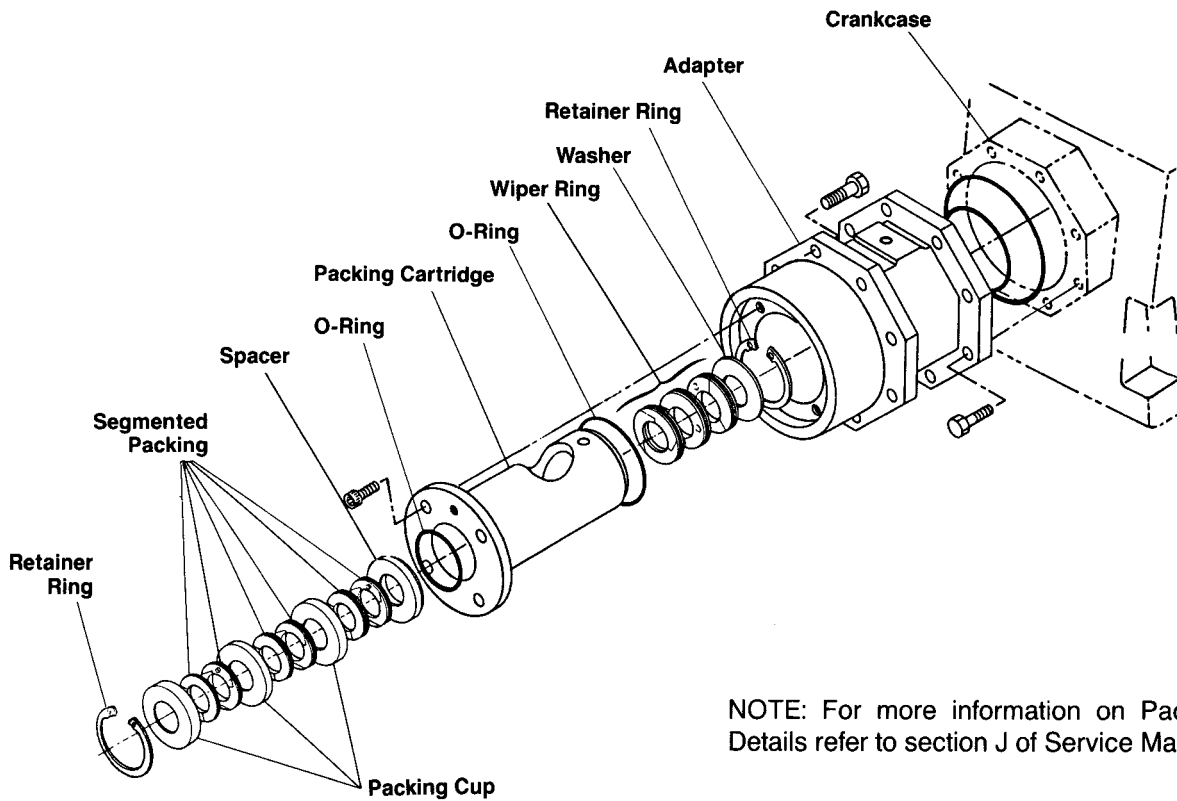

FIGURE 3. Packing Arrangement

5. The valve assembly can now be lifted out for cleaning and inspection. Visual inspection will indicate if a spring or valve disc is broken or dirty. When replacing the valve, be sure the gaskets are properly sealed. Gaskets and O-rings are not normally reusable.
6. Replace valve assembly and cage.
7. Replace cover plate and tighten bolts to 40 ft./lb. CAUTION: Be sure the holddown screw has been removed before tightening cover plate.
8. Replace holddown screw tightly enough to indent gasket.
9. Replace valve cap.

PACKING REPLACEMENT AND INSPECTION (See Fig. 3)

Before starting work be sure the compressor is vented and depressurized, and power is disconnected.

1. Remove the head, piston and cylinder. (Cylinder need not be removed on 6" and 8" sizes).
2. Remove the four socket head screws which hold the packing cartridge.
3. Remove the packing cartridge (puller holes are provided).
4. Replace the packing as required.
5. Replace the packing cartridge and screws. NOTE: The cartridge can only be installed in one position.
6. Replace the cylinder, piston and head. See Service Manual page J202 for piston clearance dimensions. Piston locknut should be torqued to 150 ft./lbs.

DRY CYLINDER COMPRESSORS

It is unrealistic to expect the same piston ring life from a Dry Cylinder Compressor as from a lubricated cylinder machine because the Teflon rings have greater wear, particularly under high temperature conditions.

CORKEN uses one of the best Teflon* ring formulations available, and the normal life expectancy of these rings is 2200 hours continuous service within recommended compression ratios, although longer life is common. Obviously, this can vary considerably with piston speed (RPM), ambient temperature, intermittent service conditions, compression ratio and the nature of the gas being handled.

The secret to long ring life is low temperature operation. The lower the ambient temperature, the better the intercooling; the lower the compression ratio, then the better the ring wear.

LUBRICATED CYLINDER COMPRESSORS

If your compressor is equipped with cylinder lubrication you can expect considerably longer life from your piston rings than the dry cylinder units described above.

**Teflon is a registered trademark of DuPont.*

ASSEMBLING OR CHANGING CYLINDERS ON HORIZONTAL COMPRESSORS

1. Keep foreign material out of crosshead bore on crankcase. Wipe inside of bore with clean rag and coat bore with oil.
2. Inspect piston rod for cleanliness and coat with oil before assembly.
3. Before installing adapter and packing cartridge on rod, install packing installation cone (Corken #3905) over piston rod threads. This will aid and protect packing during installation. Failure to use this packing cone could result in packing damage. Refer to page J252 of Service Manual for correct installation of packing.
4. Rotate crankshaft by hand several revolutions to ensure proper fit of all assembled parts.
5. Orient cylinder inlet and outlet to piping installation to ensure proper valve alignment with system. Valves must be properly oriented with suction and discharge piping.
6. Before installing piston in cylinder, be sure thrust washer is first installed against piston rod shoulder. Next, install proper shim washers to adjust crank and clearances. Piston lock nut must be torqued to 150 Ft./Lbs. before checking clearances. A valve must be removed to check clearances on both the crank end and head end of cylinder. Piston cap must be tightened to check head end clearances. Proper shims should be added to adjust head end clearances. Refer to page J202 of Service Manual for correct piston assembly and clearances. Torque piston cap screws to 8 Ft./Lbs.
7. Again, rotate crankshaft by hand several revolutions to ensure proper fit of all assembled parts.
8. Check crankcase for proper oil level.
9. See start-up procedure in Instruction Manual (IJ100). During start-up, listen to compressor for any unusual noises. If any problems arise during assembly, contact factory.

WARNING:

Corken is not responsible for assembly of our equipment by anyone other than our factory personnel.

COMPRESSOR TROUBLE SHOOTING

GENERAL

In most cases problems with your CORKEN gas compressor can be solved quite simply. Table 5 lists some of the more frequent problems that occur with reciprocating compressors along with a list of possible causes. If you are having a problem which is not listed or if you cannot find the source of the problem, consult the factory.

TABLE 5. Compressor Trouble Shooting Guide

PROBLEM	POSSIBLE CAUSES
Low Capacity	1, 2, 3, 4
Overheating	1, 2, 3, 5, 6, 11
Knocks, Rattles & Noise	1, 7, 9, 10, 11, 14
Abnormal Piston Ring Wear	1, 3, 5, 6, 11, 14
Product Leaking Through Crankcase Breather	8, 15
Product Leakage	4, 8, 14
Oil Leakage Around Compressor Base	15, 16
No Oil Pressure	17, 18
Excessive Vibration	1, 7, 9, 10, 11, 12, 13, 14, 26
Motor Overheating or Starter Tripping Out	19, 20, 21, 22, 23, 24, 25

TABLE 5. Compressor Trouble Shooting Guide (cont.)

REF.	POSSIBLE CAUSES	WHAT TO DO
1	Valves broken, stuck or leaking	Inspect and clean or repair
2	Piston ring worn	Inspect and replace as necessary
3	Inlet strainer clogged	Clean or replace screen as necessary
4	Leaks in piping	Inspect and repair
5	Inlet or ambient temperature too high	Consult Factory
6	Compression ratio too high	Check Application and consult Factory
7	Loose sheave or belt	Tighten
8	Worn piston rod packing	Replace
9	Worn wrist pin or wrist pin bushing	Replace
10	Worn connecting rod bearing	Replace
11	Unbalanced load	Inspect valves or consult Factory
12	Inadequate compressor base	Strengthen, replace or gout
13	Improper foundation or mounting	Tighten mounting or rebuild foundation
14	Loose valve, piston or packing	Tighten or replace as necessary
15	Leaking gas blowing oil from crankcase	Replace packing
16	Bad oil seal	Replace
17	No oil in crankcase	Add oil accordingly
18	Oil pump malfunction	See "Oil Pressure Adjustment"
19	Low voltage	Check line voltage with motor nameplate. Consult Power Company.
20	Motor wired wrong	Check wiring diagram
21	Wire size too small for length of run	Replace with correct size
22	Wrong power characteristics	Voltage, phase and frequency must coincide with motor nameplate. Consult with Power Company.
23	Wrong size heaters in starter	Check and replace according to manufacturer's instructions
24	Compressor overloading	Reduce speed
25	Motor shorted out	See "Driver Installation"
26	Bad Motor Bearing	Lubricate according to manufacturer's instructions.

TWO-STAGE COMPRESSOR TROUBLE SHOOTING

Two-Stage Compressors can have problems that never occur with single-stage machines. Interstage pressure is an important indicator of the condition of a two-stage Compressor.

If interstage pressure is too high:

1. Second stage valves may be broken or leaking.
2. Second stage piston rings may be worn.

If interstage pressure is too low:

1. First stage valves may be broken or leaking.
2. First stage piston rings may be worn.

If suction and/or discharge pressures change, the interstage pressure will also change.

EXTENDED SHUTDOWN PROCEDURES

Properly preparing a unit for extended shutdown will minimize future start-up problems.

1. Drain the crankcase oil & refill with a rust inhibiting oil.
2. Operate for a few minutes while fogging oil into the compressor suction.
3. Relieve V-belt tension.
4. Plug all openings to prevent entry of insects & moisture. (The cylinders may also be protected by the use of a vapor phase inhibitor, silica gel, or dry nitrogen gas. If the silica gel is used, hang a tag on the unit indicating that it must be removed before startup.)
5. Store in a dry area, off the ground if possible.
6. Rotate the flywheel every 2 weeks if possible.

EXTERNAL LUBRICATORS USED ON CORKEN COMPRESSORS

MADISON-KIPP Model DSL Lubricator Data:

ROTATION: Either Direction

MAX. OPERATING PRESSURE: 3000 psig

INLET AND OUTLET SIZE: 1/8" NPT

DELIVERY PER PLUNGER STROKE: Adjustable 0 - 3.4 drops

0 - 0.008 cubic inches

MAX. DELIVERY/MIN:

Compressor RPM X .0063 X Delivery per Stroke Vertical Units 190-690

Compressor RPM X .0151 X Delivery per Stroke Vertical Units 791 - 891

Compressor RPM X .012 X Delivery per Stroke Horizontal Units

(Basic drop size equals 0.0024 cubic inches)

NOTE: The lubricator supplied on your CORKEN compressor must be supplied with oil from an external supply tank, **NOT** from the compressor crankcase, or lubricator reservoir.

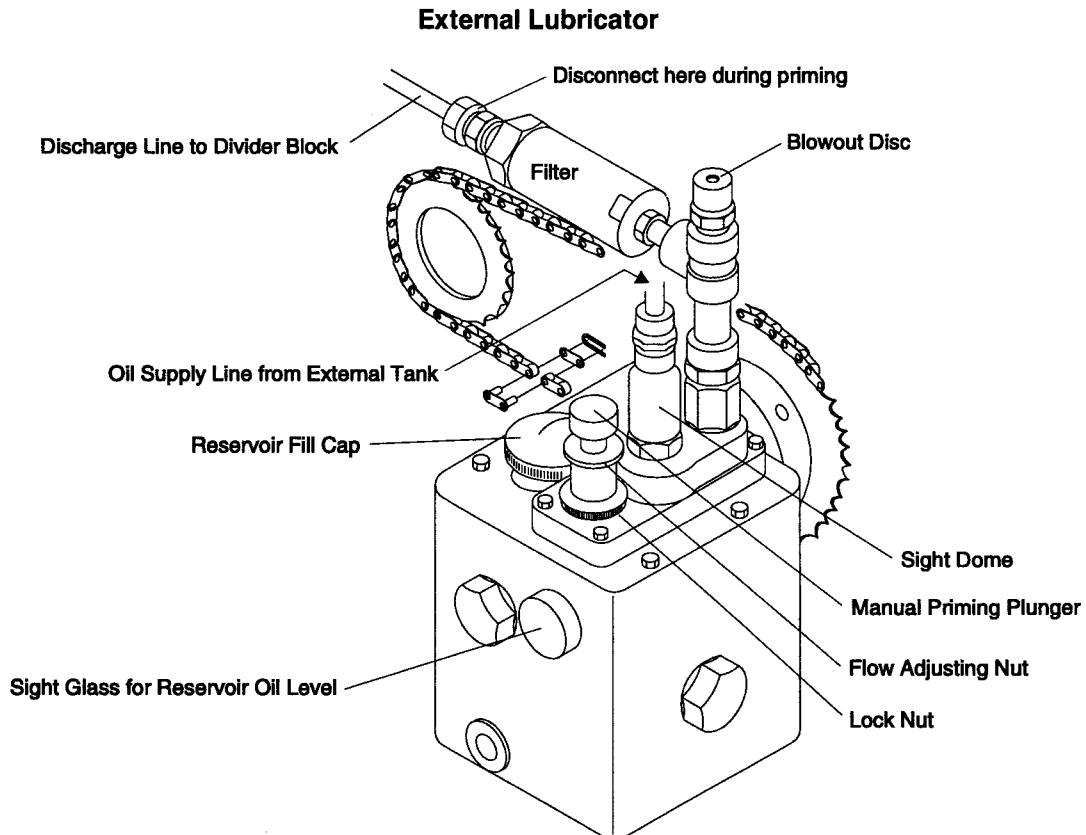

The Madison-Kipp DSL lubricator is manufactured and designed so that each pumping unit can be individually adjusted for the exact amount of lubricating oil to be fed to a given position.

The operation and adjustment methods are described on a metal instruction plate attached to the side of the lubricator reservoir.

TO START:

1. Check that all tubing is free of any kinks. Any replacement tubing should be clean and the ends free of burrs.
2. Fill reservoir with oil.
3. If oil is visible in sight dome, go to Step 7.
4. Remove the sight dome.
5. Fill the pump chamber with oil.
6. Replace the sight dome (finger tight only).
7. Connect tubing between top of sight dome and external supply tank.
8. Remove the discharge tubing from the filter.
9. Prime by manually pumping plunger in front of sight dome until air bubbles are purged and oil is clear.
10. Reconnect the discharge tubing to the filter.
11. Operate the compressor manually to check stroke, alignment and operation.
12. Additional precautions taken at this time will eliminate the possibility of malfunction and prevent damage to your lubricator or equipment.

TO ADJUST FLOW:

1. Loosen lock nut on flow adjusting nut.
2. To increase flow, turn adjusting nut counter-clockwise; to decrease, turn clockwise.
3. Tighten lock nut.

TO MAINTAIN AT PEAK PERFORMANCE:

1. Use only clean oil.
2. Keep lubricator reservoir full of oil.
3. See that all connections are tight.
4. See that oil leads are supported where excessive vibration occurs.
5. Check lubricator drive system to ensure that all components are in alignment and good condition.
6. Make sure all mounting bolts are tight.

HORIZONTAL COMPRESSOR BOLT TORQUE VALUES

SIZE	CONN. ROD BOLT FT-LB	BEARING CARRIER FT-LB	BEARING COVER FT-LB	CRANK-CASE INSPEC PLATE FT-LB	ADAPTER TO CRANK-CASE (2)	CYL. TO ADAPTER FT-LB (2)	VALVE COVER PLATE BOLT FT-LB	VALVE HOLD-DOWN SCREW (3) FT-LB	PISTON NUT TORQUE FT-LB	PISTON SCREW TORQUE IN-LB	VALVE/ UNLOADER CAP TORQUE FT-LB	(3-4 STG ONLY) CYL. TO CYL. (2)	HEAD TO CYL. (2)
2¼	40	40	40	8	65	65	CF	40	150	100	25	--	65
3¼	60	30	30	8	65	65	35	40	150	50	25	--	65
4	60	30	30	8	65	65	37	40	150	100	25	--	65
6	60	30	30	8	65	65	37	40	150	100	25	--	65
8	60	30	30	8	65	65	37	40	150	100	25	--	65
2¼ on 6 (1)	60	30	30	8	65	65	--	40	150	100	25	65	90
¼ on 3¼ (1)	60	30	30	8	65	65	--	40	150	100	--	65	90

(1) 3-4 stage CNG models..

(2) Preliminary tightening - snug all headbolts in the sequence shown. Final torquing - torque all headbolts in the sequence shown to the listed value.

(3) Retorque to the listed value after 2-5 hours running time.

TIGHTENING SEQUENCE - ALL MODELS

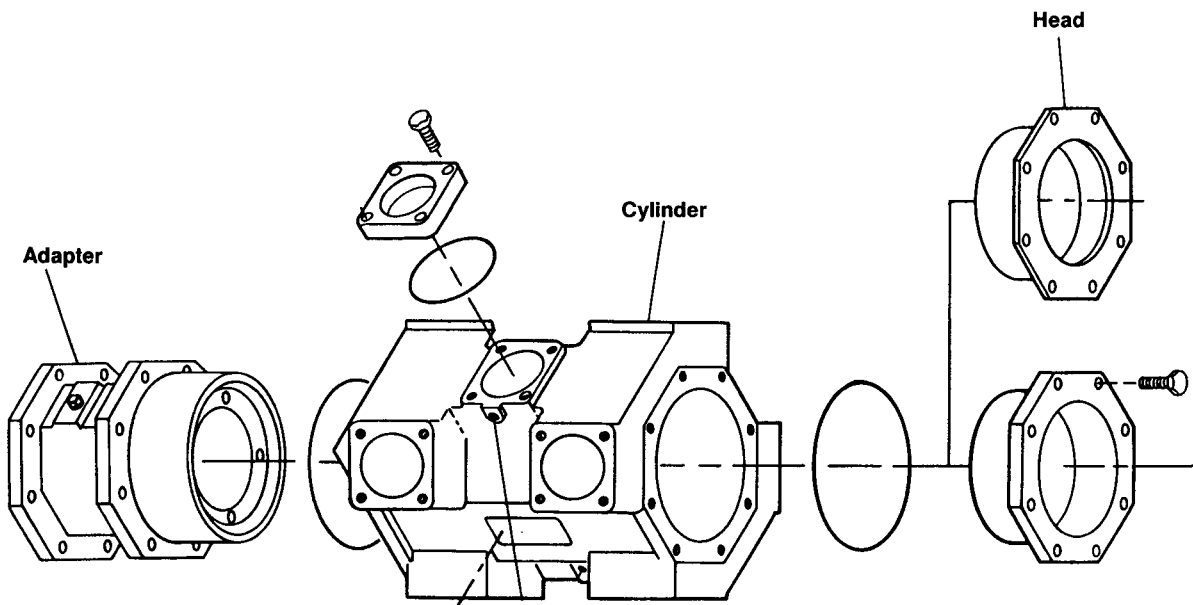
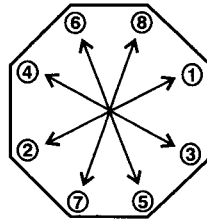

CORKEN COMPRESSOR LOG SHEET

(ELECTRIC DRIVEN UNITS)

Compressor Model # _____ Serial # _____

Cylinder Serial #'s _____, _____ RPM _____

Motor BHP _____, Frame _____, RPM _____, F.L. Amps _____, Manuf. _____

Packager _____ Package # _____

Installation Date _____ Startup Date _____

Customer _____

Location _____

Field Contact _____ Tel. # _____

Make & Grade of Oil _____

Pressure Switch Settings	Stage 1	Stage 2
Suction Pressure	_____	_____
Discharge Pressure	_____	_____

Cylinder Lube Pump Rate _____

Date _____ Time _____ Outside Temp. _____ Hour Meter _____

Readings:	Stage 1	Stage 2
Suction Pressure	_____	_____
Discharge Pressure	_____	_____
Suction Temperature	_____	_____
Discharge Temperature	_____	_____

Check list:

- | | |
|-----------------------|-----------------------------------|
| _____ Oil Level | _____ Cyl. Lube Pump Oil Level |
| _____ Change Oil | _____ Cyl. Lube Pump Supply Level |
| _____ Flywheel Bolts | _____ Cyl. Lube Pump Feed Rate |
| _____ Mounting Bolts | _____ Belt Tension |
| _____ Motor Amperage | _____ Gauges (zero position) |
| _____ Strainers | _____ Packing Vents |
| _____ Valve Positions | _____ Drain Separators |
| _____ Dump Valves | _____ Unloaders |

Additional Notes:

Checked by _____

CORKEN[®]
IDEX

P.O. Box 12338, Oklahoma City, OK 73157
3805 N.W. 36th St., Oklahoma City, OK 73112
Phone (405) 946-5576 • Fax (405) 948-7343