

Industrial Compressors

Plain and T-Style, Double-Acting Gas Compressors
Models HG601, HG602, THG601, and THG602 Series

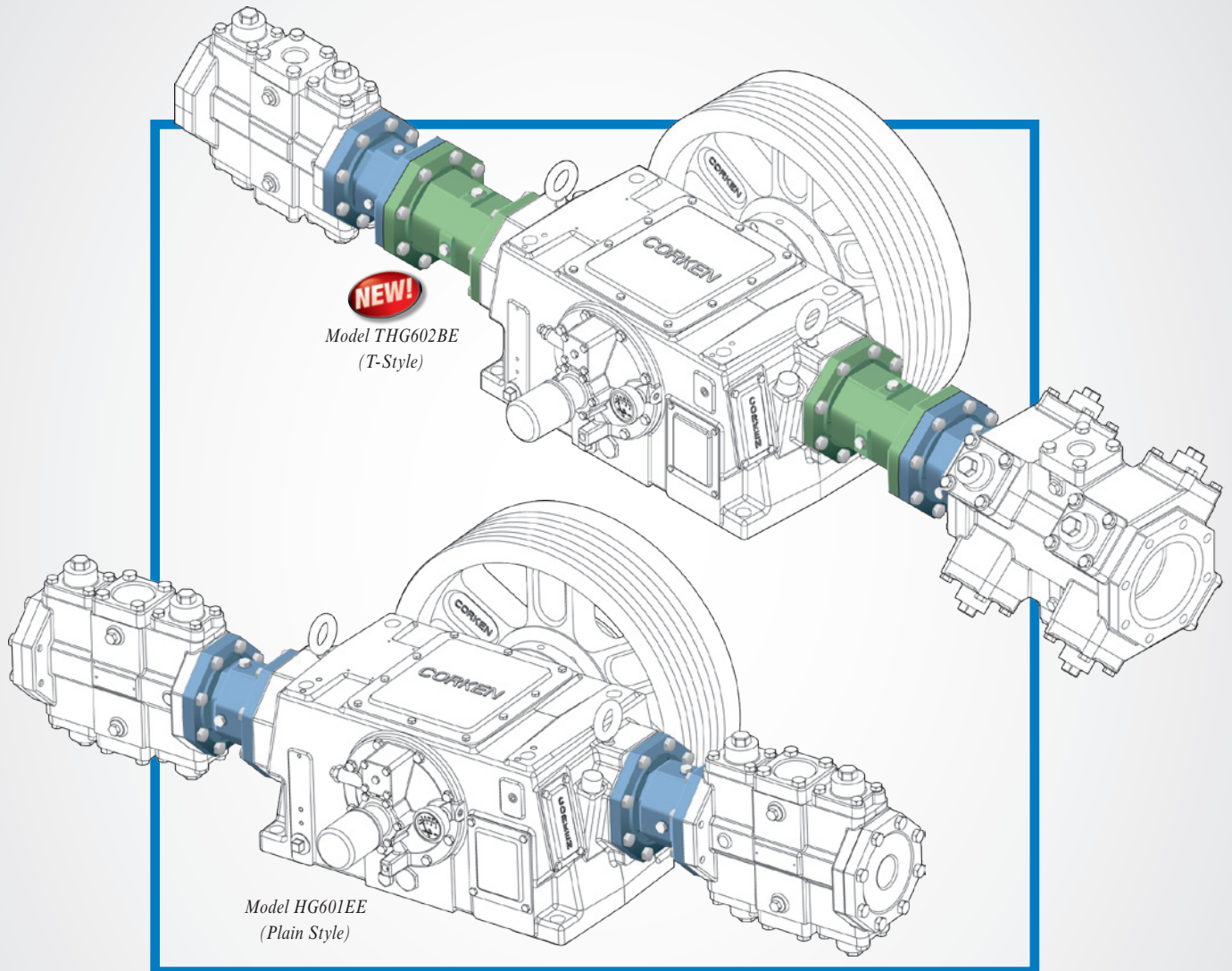

Solutions beyond products...

**CORKEN**[®]
IDEX

Meeting the Environmental Standards for Fugitive Emissions Control

NEW! T-Style Design...

Corken now offers a new T-Style horizontal compressor for applications where leakage control is critical. The T-Style design has three sets of packing that create two distance pieces that can be purged or padded for maximum leakage control or containment.

When properly equipped with a purge kit, Corken's double-distance piece (T-style) provides precise leakage control and complies with the EPA's requirements for fugitive emissions control of volatile organic compounds (VOC) U.S. Environmental Protection Agency Regulations 40 CFR CH Section 264 .1053.

For corrosive applications, Corken offers a special MC1002 coating that prevents corrosion and wear of critical parts within the compressor. The MC1002 coating is a nickel alloy plating which is impregnated with fluorocarbons. Optional materials for compressor parts are available for various gases as required.

No contamination of process gas stream...

To meet the stringent requirements of today's markets, Corken's new T-Style (double-distance piece) horizontal compressors are oil free. The T-Style has three sets of segmented packing to help control oil carryover. In addition, the extra space between the crankcase and the compression chamber eliminates rod over travel. In other words, the portion of the piston rod that comes into contact with the first set of packing will never reach the second set of packing while the portion of the piston rod that comes into contact with the second set of packing will never reach the third set of packing.

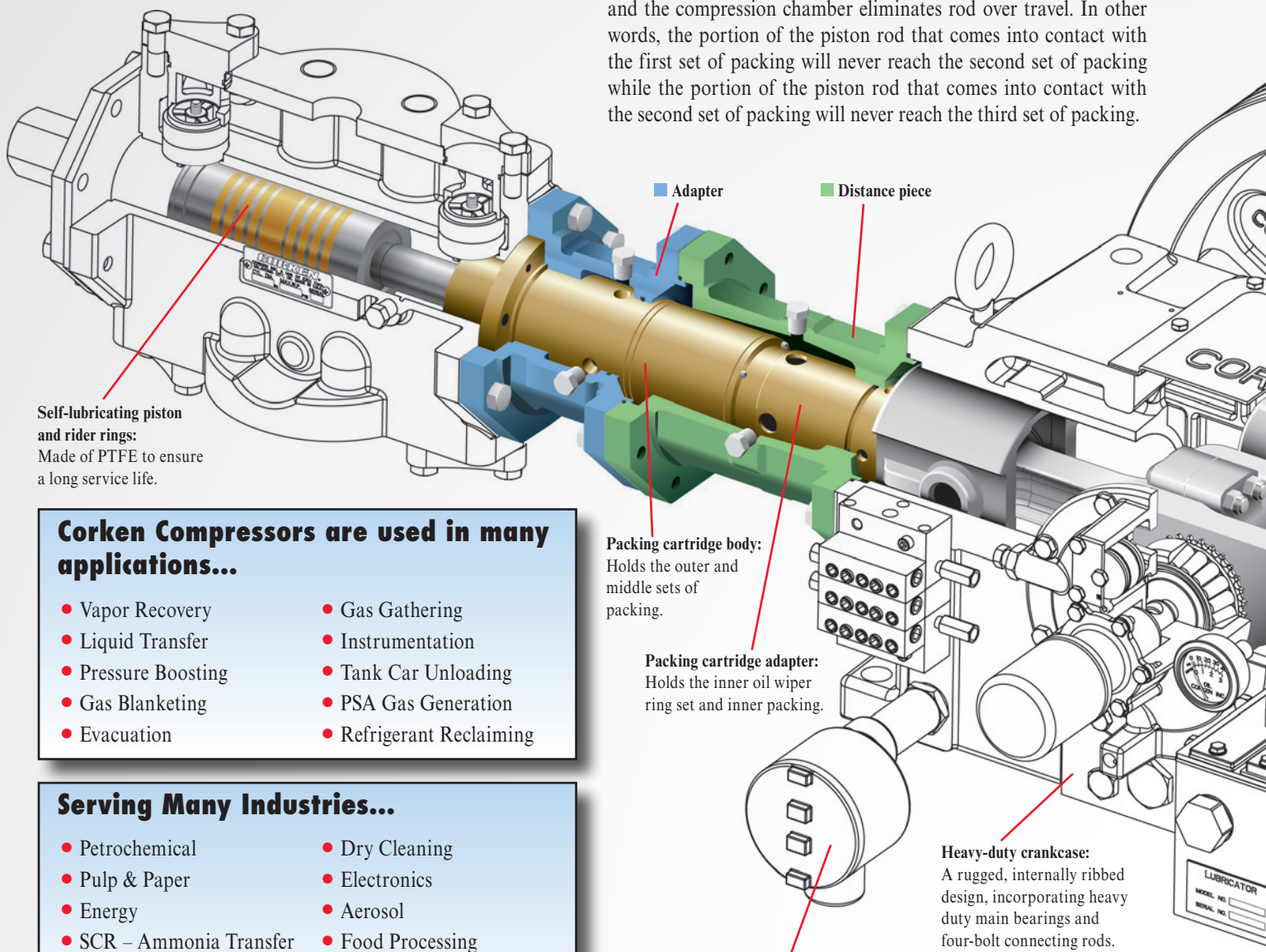

Self-lubricating piston and rider rings:
Made of PTFE to ensure a long service life.

Corken Compressors are used in many applications...

- Vapor Recovery
- Liquid Transfer
- Pressure Boosting
- Gas Blanketing
- Evacuation
- Gas Gathering
- Instrumentation
- Tank Car Unloading
- PSA Gas Generation
- Refrigerant Reclaiming

Serving Many Industries...

- Petrochemical
- Pulp & Paper
- Energy
- SCR – Ammonia Transfer
- Transportation
- Utilities
- Dry Cleaning
- Electronics
- Aerosol
- Food Processing
- Health Care

Packing cartridge body:
Holds the outer and middle sets of packing.

Packing cartridge adapter:
Holds the inner oil wiper ring set and inner packing.

Heavy-duty crankcase:
A rugged, internally ribbed design, incorporating heavy duty main bearings and four-bolt connecting rods.

(Optional) Thermostatically controlled crankcase heater:
Assures proper oil viscosity throughout all weather conditions.

Model THG602BF shown above

Double-Distance Piece Can Be Pressurized, Purged or Vented

New T-Style double-distance piece for maximum leakage containment...

The T-Style (THG601 and THG602) is an oil-free design that has one set of oil wiper rings and three sets of packing that form two distance pieces or barriers to external leakage (see figure below). For a wide range of application flexibility, each distance piece has its own line connections and can be pressurized, purged or vented separately. This allows you to choose the best method of containment based on the requirements of your specific application. For added convenience, purge kits with all of the accessories needed to control the purging or pressurization of each chamber are available. T-Styles are typically used in corrosive or toxic applications where leakage containment and non-contamination of the gas stream are critical.

Single packed plain style is used for standard leakage containment...

The plain style (HG601 and HG602) has one set of oil wiper rings and one set of packing and is not oil free. This version is typically used in non-corrosive, non-toxic services where oil-free gas is not required and leakage containment is not critical. Examples are natural gas (oilfield) and some air boosting applications.

Available in single- or double-acting configurations...

The plain and T-Style horizontal compressors are available in single- or double-acting configurations. Single-acting configurations are ideal for applications that require low flow and high pressure while double-acting configurations offer maximum capacity. Single-acting configurations require the use of a blank valve option.

Sized for your capacity & pressure needs...

Since Corken's horizontal compressors are available with a variety of cylinder sizes ranging from 8 to 2.75 inches, they can provide a wide range of flows and pressures to meet your specific requirements. The cylinder sizes may be arranged in various combinations of single- and two-stage units.

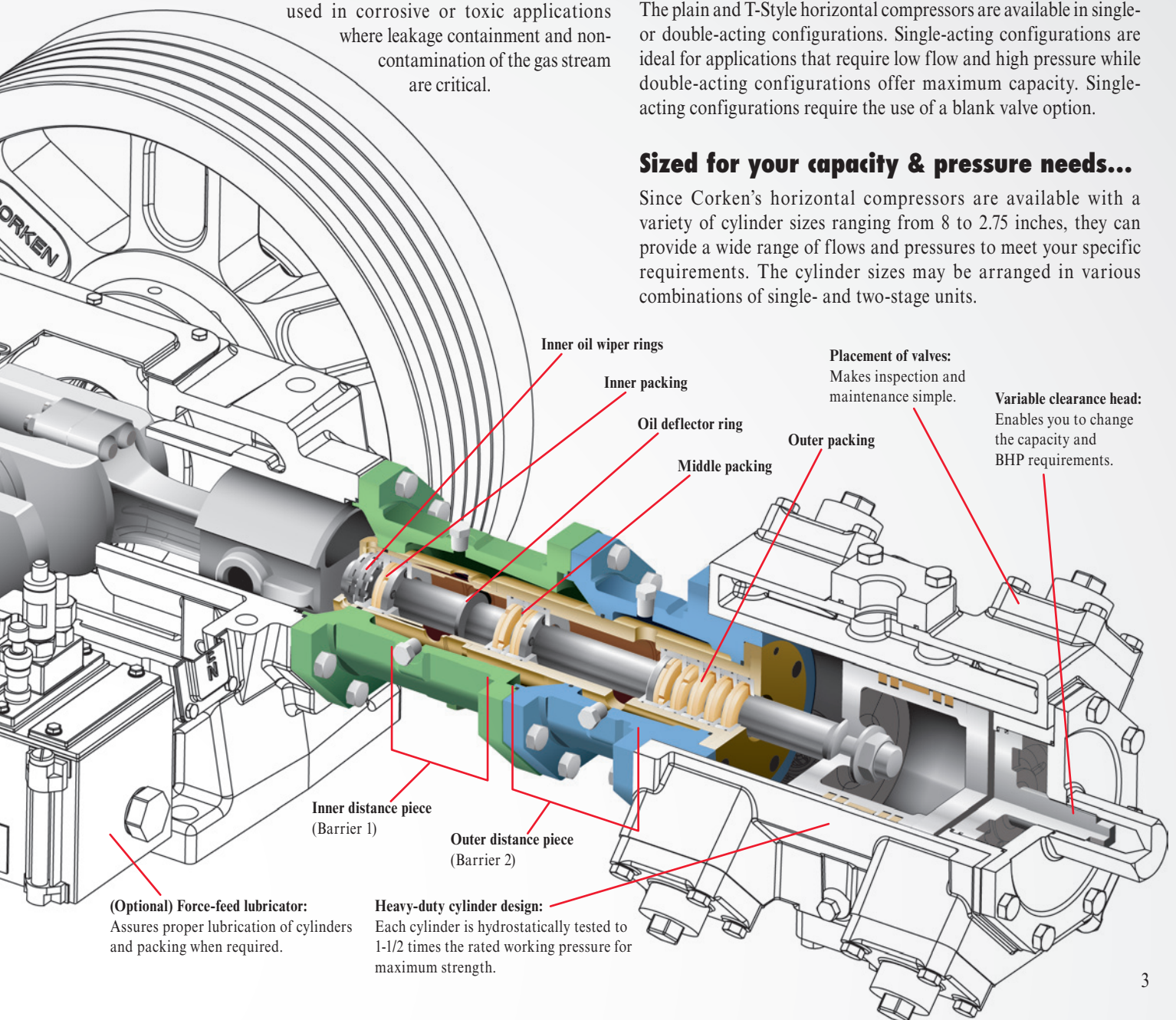

Single-Stage Horizontal Compressors

Single Cylinder Models	HG601AX THG601AX	HG601BX THG601BX	HG601CX THG601CX	HG601DX THG601DX	HG601EX THG601EX	HG601FX THG601FX
Size	8"	6"	5"	4"	3.25"	2.75"
Displacement cfm (m ³ /hr)						
400 rpm	68.8 (116.9)	38.4 (65.2)	26.4 (44.9)	16.8 (28.5)	10.8 (18.3)	7.6 (12.9)
1200 rpm	207.0 (351.7)	115.0 (195.4)	79.2 (134.4)	49.8 (84.6)	32.2 (54.5)	22.8 (56.0)
Approximate shipping weight lb. (kg.)						
HG model	730 (331.1)	650 (295.0)	640 (290.3)	630 (285.8)	620 (281.2)	620 (281.2)
THG model	780 (353.8)	700 (317.5)	690 (313.0)	680 (308.4)	670 (303.9)	670 (303.9)
Two Cylinder Models	HG601AA THG601AA	HG601BB THG601BB	HG601CC THG601CC	HG601DD THG601DD	HG601EE THG601EE	HG601FF THG601FF
Size	8" x 8"	6" x 6"	5" x 5"	4" x 4"	3.25" x 3.25"	2.75" x 2.75"
Displacement cfm (m ³ /hr)						
400 rpm	138 (234.5)	76.8 (130.5)	52.8 (89.7)	33.2 (56.4)	21.2 (36.0)	14.8 (25.1)
1200 rpm	414 (704)	231 (393)	158.4 (268.8)	99.6 (169.2)	64 (108.7)	44.4 (75.6)
Approximate shipping weight lb. (kg.)						
HG model	1,070 (485.4)	910 (412.8)	890 (403.7)	870 (394.6)	845 (383.3)	845 (383.3)
THG model	1,170 (530.7)	1,010 (458.1)	990 (449.1)	970 (440.0)	945 (428.7)	945 (428.7)

Two-Stage Horizontal Compressors

Two Cylinder Models	HG602AB THG602AB	HG602AC THG602AC	HG602AD THG602AD	HG602BC THG602BC	HG602BD THG602BD	HG602BF THG602BF
Size	8" x 6"	8" x 5"	8" x 4"	6" x 5"	6" x 4"	6" x 2.75"
Displacement cfm (m ³ /hr)						
400 rpm	68.8 (116.9)	68.8 (116.9)	68.8 (116.9)	38.4 (65.2)	38.4 (65.2)	38.4 (65.2)
1200 rpm	207.0 (351.7)	207.0 (351.7)	207.0 (351.7)	115.0 (195.4)	115.0 (195.4)	115.0 (195.4)
Approximate shipping weight lb. (kg.)						
HG model	990 (449.1)	980 (444.5)	970 (440.0)	930 (421.9)	895 (406.0)	880 (399.2)
THG model	1,090 (494.4)	1,080 (489.9)	1,070 (485.4)	1,030 (467.2)	995 (451.3)	980 (444.5)
Two Cylinder Models	HG602BE THG602BE	HG602CD THG602CD	HG602CF THG602CF	HG602DE THG602DE	HG602DF THG602DF	HG602EF THG602EF
Size	6" x 3.25"	5" x 4"	5" x 2.75"	4" x 3.25"	4" x 2.75"	3.25" x 2.75"
Displacement cfm (m ³ /hr)						
400 rpm	38.4 (65.2)	26.4 (44.9)	26.4 (44.9)	16.8 (28.5)	16.8 (28.5)	10.8 (18.3)
1200 rpm	79.2 (134.4)	79.2 (134.4)	79.2 (134.4)	49.8 (84.6)	49.8 (84.6)	32.2 (54.5)
Approximate shipping weight lb. (kg.)						
HG model	880 (399.2)	880 (399.2)	867 (393.3)	860 (390.1)	860 (390.1)	845 (383.3)
THG model	980 (444.5)	980 (444.5)	967 (438.6)	960 (435.5)	960 (435.5)	945 (428.7)

Cylinder Data

Description	Cylinder Code					
	A	B	C	D	E	F
Cylinder bore in. (mm)	8 (203.2)	6 (152.4)	5 (127)	4 (101.6)	3.25 (82.6)	2.75 (69.9)
Maximum working pressure psig (bar g)	300.0 (20.7)	350 (24.1)	750 (51.7)	1,000.0 (69.0)	1,200.0 (82.8)	1,650.0 (113.8)

Frame Data

Stroke inches (mm)	3.0 (76.2)
Maximum gas rod load lb (kg)	7,000 (3,175.2)
Maximum motor size hp (kW)	75 (55.9)
Maximum discharge temp °F (°C)	350.0 (176.7)
Minimum temp °F (°C)	-25 (-31.6)
RPM range	400 - 1,200

Solutions beyond products...



Corken, Inc. • A Unit of IDEX Corporation
3805 N.W. 36th St., Oklahoma City, OK 73112 U.S.A.
Phone (405) 946-5576 • FAX (405) 948-7343

Visit our website at <http://www.corken.com> • E-mail us at info.corken@idexcorp.com